

LED BUNKER LIGHT

SE7087L REC-BUNKER

CONSTRUCTION

- Die-cast aluminium body
- Powder coated finish
- Opal polycarbonate diffuser
- Stainless steel screws
- Silicon gasket
- High efficiency SMD LED chips
- Constant current non-dimmable LED driver fitted

IP RATING

- IP54 weatherproof

DIMMING OPTIONS

- Trailing edge



DIMENSIONS



Model No.	Input	Power	Lumen	CCT	Beam Angle	CRI	Fitting Colour
SE7087L	240V	18W	1450lm	4000K	90°	>80	White

LED WALL LIGHT

SE7089 BRONX

CONSTRUCTION

- Die-cast aluminium body
- Powder coated finish
- UV stabilised opal polycarbonate diffuser
- High efficiency COB LED chip
- Polished aluminium reflector
- Built-in constant current non-dimmable LED driver
- IP66 PVC cable gland
- Stainless steel allen screws
- 450 mm 3 core rubber flex

IP RATING

- IP65 weatherproof

SENSOR OPTIONS

- Integrated microwave motion sensor



DIMENSIONS

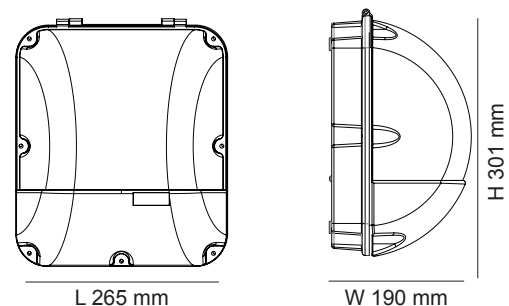

Model No.	Input	Power	Lumen	CCT	CRI	Fitting Colour
SE7089BK	240V	55W	4500lm	5000K	>70	Black