

LED INGROUND LIGHT

S9341 GROUND MKII

IP67

CONSTRUCTION

- 316L stainless steel face cover
- Die-cast aluminium body
- Clear tempered glass diffuser
- High efficiency SMD LED chips with optical lens
- Built-in constant current non-dimmable LED driver
- Silicon gasket
- IP68 PG9 PVC cable gland
- Stainless steel allen screws
- PVC installation canister included
- 450 mm 3 core rubber flex

IP RATING

- IP67 weatherproof

LOAD PRESSURE CAPACITY

- Maximum 2000 kg



DIMENSIONS

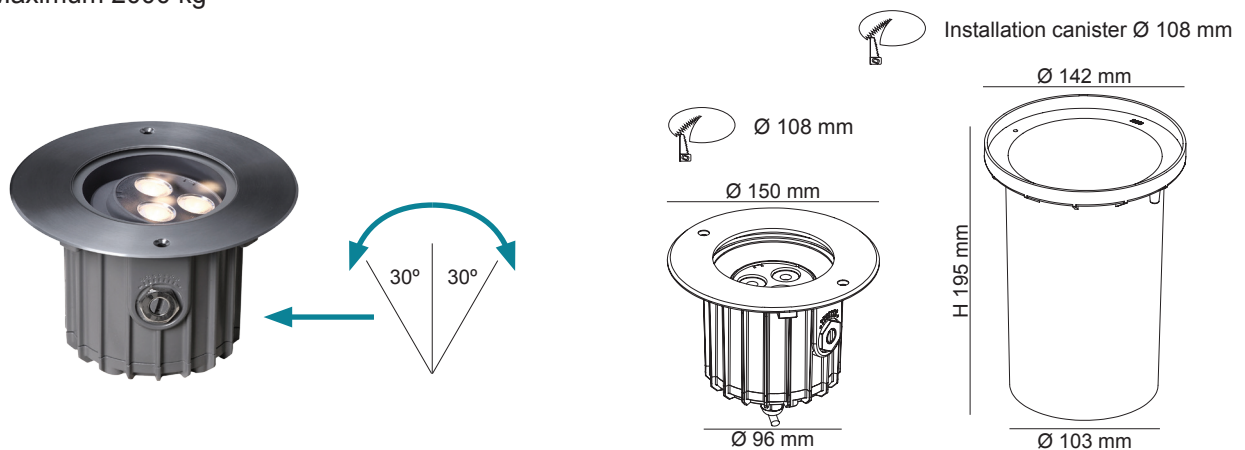

Model No.	Input	Power	Lumen	CCT	Beam Angle	CRI	Fitting Colour	Load Pressure Capacity
S9341WW	240V	8W	350lm	3000K	30°	>80	Stainless Steel	2000 kg
S9341CW	240V	8W	400lm	4000K	30°	>80	Stainless Steel	2000 kg

