

FORTRESS



Fortress Twin Spot 3000K

Martec's Fortress Twin Spot exterior light provides exceptional light coverage thanks to a state-of-the-art COB LED chip at low energy costs. The twin spot LED Fortress has two articulating arms, each with a highly efficient COB LED, and the added benefit of being IP65 rated to survive the harshest outdoor environments.



FEATURES

- /// Long life energy saving LED
- /// Available in a durable brushed nickel, white or matt black
- /// Twin COB LED spot light
- /// High quality aluminium frame acts as heat-sink
- /// Modern, architectural outdoor landscape lighting
- /// Sleek design seamlessly integrates into house exterior
- /// IP65 rating for outdoor environments
- /// 3 Year replacement warranty

TECHNICAL INFORMATION

Power: 26W (2 x 13W)
CCT: 3000K (Warm White)
Lumens: 925 lm (per head)
Beam Angle: 120°

DIAGRAMS

Lux Distance Curve

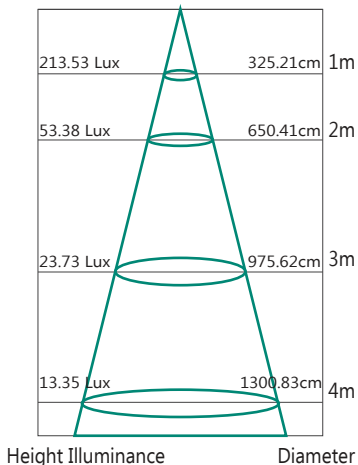

Light Distribution Curve (Unit: cd)

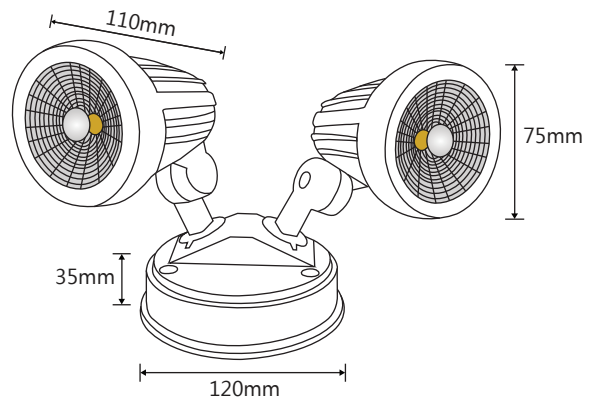
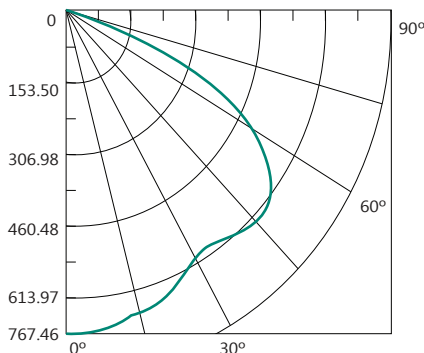

MLXF302B



MLXF302W



MLXF302M

