

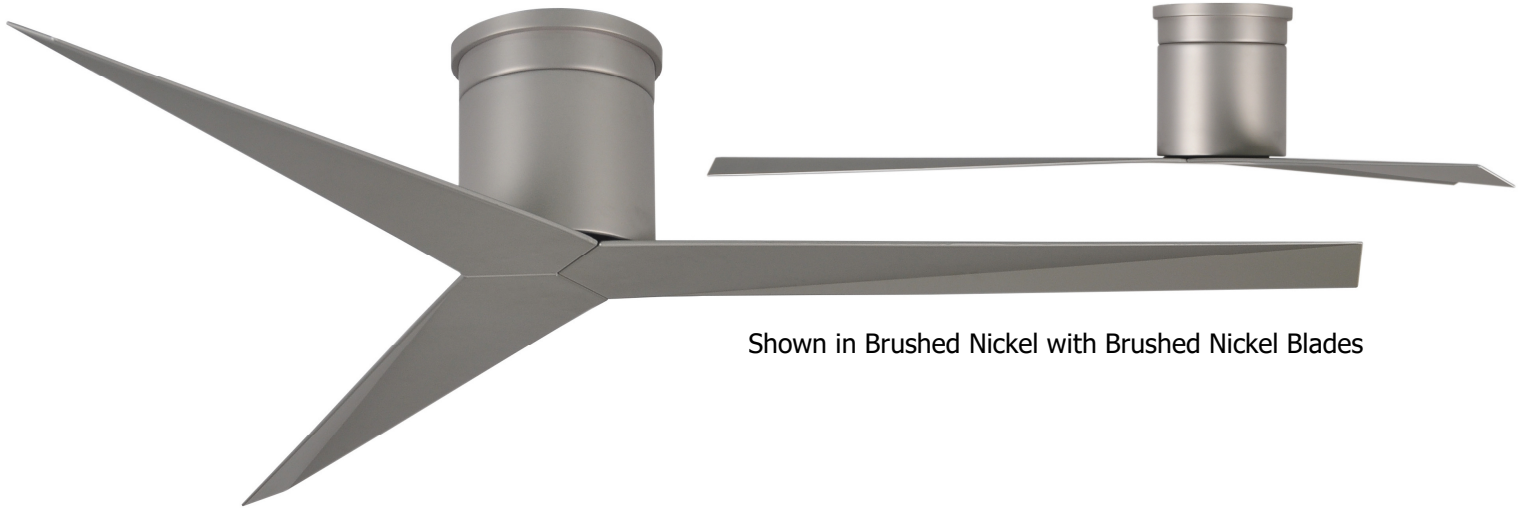

Eliza-H

Geometry in Motion

Designed in 2014



Shown in Brushed Nickel with Brushed Nickel Blades



Shown in Gloss White with Gloss White Blades

Designed by Chicago architect Stephen Katz in 2013, the wet location Eliza-H blends a beautiful technically derived form with superior function and movement. The unique blade shape is designed to maximise air movement at the outer edge of the blade. The result is more efficient air velocity rings, less blade drag and a greater motor optimisation. Equally important is Eliza'-Hs stationary visual statement which combines modern utility with minimalist geometry. Constructed of cast aluminium and heavy stamped steel, the Eliza-H has a limited lifetime warranty.

- 56"/142cm diameter with solid wood, gloss white machine-cut blades
- Energy efficient, ultra-quiet, six-speed, reversible DC motor.
- Constructed of cast aluminium and heavy stamped steel.
- Wet Location. Not recommended for salt water/ocean front applications.
- Limited Lifetime Warranty
- Standard equipment:
 - Reverse on six speed, hand-held and wall-mountable remote control.



Eliza-H

STANDARD EQUIPMENT

6-speed RF remote control with reverse function in black



WARNING:
Only compatible with included controllers.

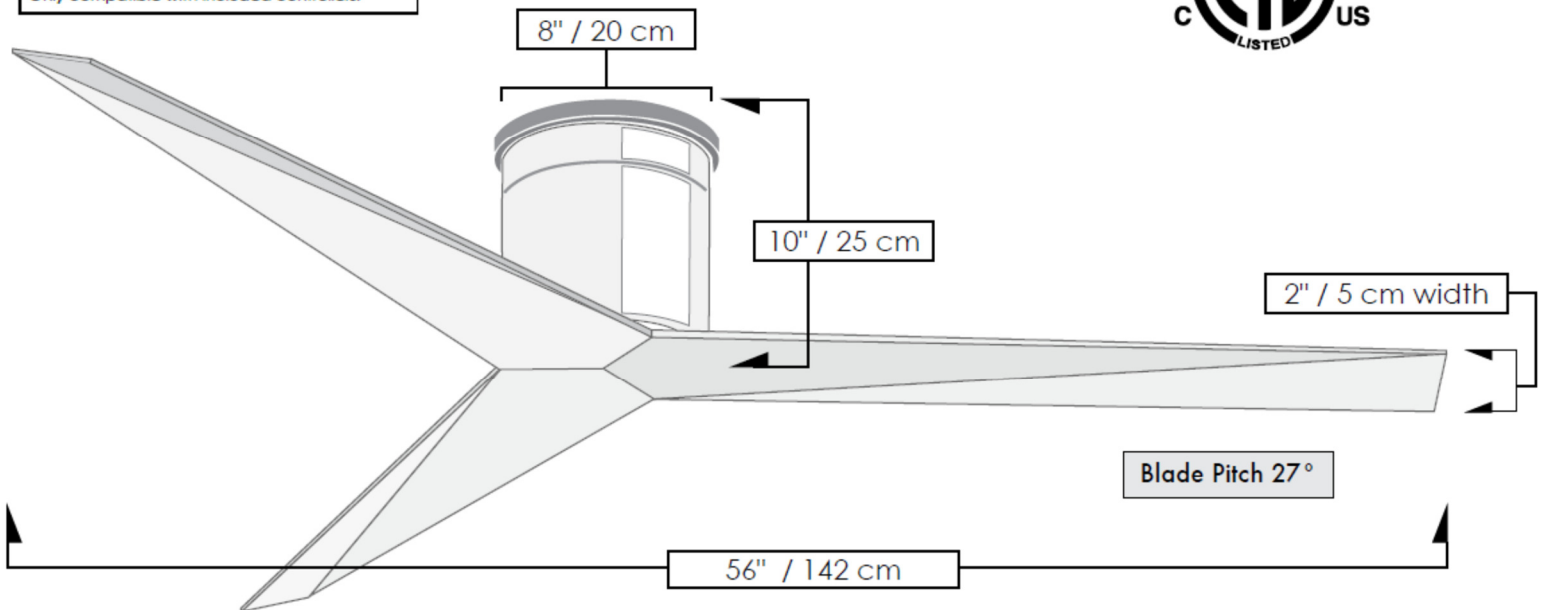

FAN SPECIFICATIONS

FAN SPECIFICATIONS	
Fan Diameter	56" / 142cm
Overall Drop	10"/25cm
Fan Weight	6.4 kgs
RPM (Low / High)	52 / 175
CMH (Low / High)	1908 / 6854
Watts (High)	33.49
Environments	Damp location for all finishes All weather blade system Not coastal, saltwater or chlorine compatible