

Mini In-ground Uplighters Square

HV2702 240v LED 1.2w

- In-ground uplighter square
- Stainless steel 316 marine grade cover
- Flush tempered glass
- Trafficable to 600kg
- Hole cut out not using plastic canister: 61mm
- Hole cut out using plastic canister: 64mm
- Installation depth needed: 98mm
- Face diameter: 70mm
- NOTE: adequate drainage must be allowed
- Cool white, 4000k, 90lm
- 240v LEDx6 (1.2w total) with built in driver
- IP rating: IP65

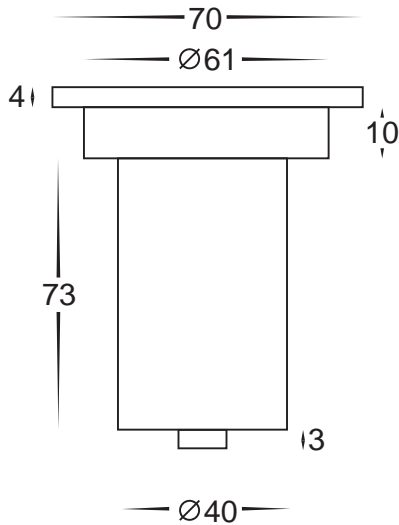

Built in 6 chip 1.2w LED

