

# Stainless Steel In-ground Uplighters Square

- In-ground uplighter square
- Stainless steel 316 marine grade cover
- Full stainless steel body
- Flush tempered glass
- Trafficable to 600kg
- Cut out not using plastic canister: 77mm
- Cut out using plastic canister: 90mm
- Face: 100mm x 100mm
- Installation depth: 175mm
- **NOTE: adequate drainage must be allowed**
- 240v GU10 35w max / 12v MR16 20w max
- IP rating: IP65
- Can be used with a halogen globe

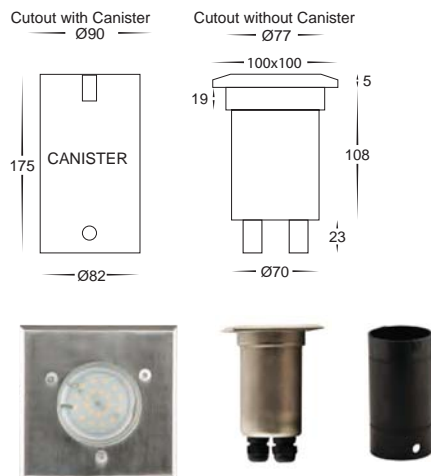

## 316 Stainless Steel In-ground Uplighters Square

IMAGE	PART NUMBER	COLOUR TEMP	OUTPUT	POWER	INCLUDED GLOBES
	<b>HV1707C</b>	Cool white, 6000k	300lm	240v LED 5w	5w LED globe
	<b>HV1707W</b>	Warm white, 3000k	250lm	240v LED 5w	5w LED globe
	<b>HV1708C</b>	Cool white, 6000k	300lm	12v LED 5w	5w LED globe
	<b>HV1708W</b>	Warm white, 3000k	250lm	12v LED 5w	5w LED globe

All globes supplied with fittings are non dimmable. If you require 240v dimmable globes refer to pages (169 - 178)

All low voltage products that specify LED or are supplied with a 12v LED globe must be used with a suitable LED driver, refer to pages (188 - 192)