

Carlton Small & Large Oval LED Bunker

Crompton's new extensive range of exterior LED bunkers are suitable for many varied applications, available in black, white, caged and plain diffused lens.



Carlton Small & Large Oval LED Bunker

The Carlton Small & Large Oval LED Bunkers are a traditional, reliable and energy efficient exterior surface mounted LED Bunker light. It is durable and beautifully lights up foyers, entrances and walkways.

Features

- Powder coated die-cast aluminium
- Frosted glass diffuser

Benefits

- Traditional, energy efficient exterior surface mounted LED bunker light
- Available in black, white, caged and plain diffused lens

Compliance

- IP54
- Non - dimmable
- Ta 40

Performance

- Large - 13W, 950 Lumen; Small – 8W, 500 Lumen
- 4000K
- 80 CRI
- 30,000 hours average lamp life

Dimensions

- Large 285W x 165H x 130D
- Small 210W x 110H x 90D

Applications

Designed for residential, foyer entrances, walkways, retaining walls and decorative corridor spaces

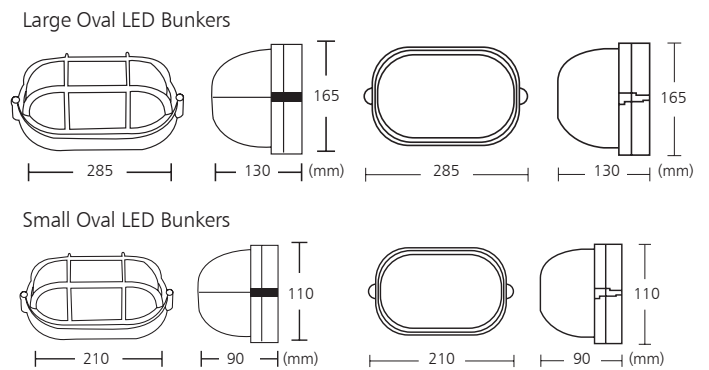

Code	Ref Number	Colour	Watts	Voltage	Style	Lumen output
27472	EXLED7100PB	Black	8W	240V	Plain	500
27473	EXLED7100PW	White	8W	240V	Plain	500
27474	EXLED7100CB	Black	8W	240V	Caged	500
27475	EXLED7100CW	White	8W	240V	Caged	500
27476	EXLED7200PB	Black	13W	240V	Plain	950
27477	EXLED7200PW	White	13W	240V	Plain	950
27478	EXLED7200CB	Black	13W	240V	Caged	950
27479	EXLED7200CW	White	13W	240V	Caged	950



Crompton is a brand of the Gerard Lighting Pty Ltd



Actual product life may vary dependant upon frequency of maintenance and product application.

crompton.com.au