

# EV-SPLASH-SQR

## Splash downlight

### Technical data sheet



#### DESCRIPTION

Domus lighting is pleased to announce the arrival of its NEW SPLASH range of LED down lights. The SPLASH LED down light has been added to our ever increasing EVERGREEN range of LED lighting products. This now extends the range of LED down lights and complements the newly released DLK range that remains at the top of the chain with regards to style, performance and pricing. Available in powdercoated satin white or silver finish.

The SPLASH series has been introduced as a cost effective solution to energy efficient down lights and offers the customer a range of features not offered by others with similar products.



#### SPECIFICATION FEATURES

- Power: 13W
- Beam Angle: 90°
- Colour Range: WW / W
- CCT: 3000K / 5000K
- Lumens Output: 849lm / 889lm
- Working Voltage: AC240V
- Size: 110 x 38mm
- Cutout size: 90mm
- Weight: 0.52kg
- Operating Temperature: -20°C - 65°C
- Certifications: CE, RoHS, SAA
- IP Rated: IP44
- Warranty: 3 years

Product code: EV-SPLASH-SQR-W-WW  
Order code: 20564  
Colour: Satin White - Warm White 3000K

Product code: EV-SPLASH-SQR-W-W  
Order code: 20565  
Colour: Satin White - White 5000K

Product code: EV-SPLASH-SQR-S-WW  
Order code: 20566  
Colour: Silver - Warm White 3000K

Product code: EV-SPLASH-SQR-S-W  
Order code: 20567  
Colour: Silver - White 5000K

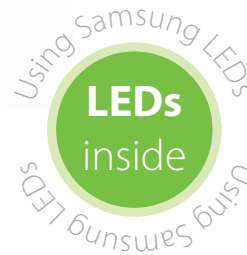

#### DIAGRAMS

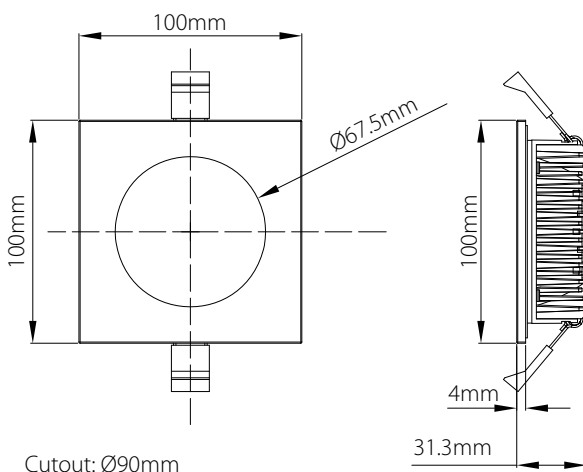

LUMINOUS INTENSITY DISTRIBUTION DIAGRAM

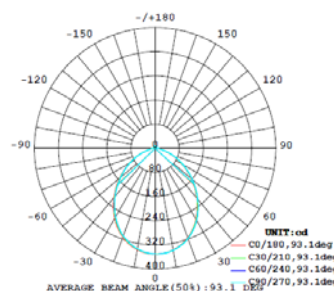

C0 PLANE ISOLUX DIAGRAM (UNIT:lx)

