

EV-FUSION-2

LED Inground Lights

Technical data sheet

DESCRIPTION

The FUSION-2 is a newly introduced item that replaces its predecessor the FUSION. The FUSION-2, now boasts an amazing lumen package and features not seen by others of similar sizing and specifications. The light source is powered from 24 x 1W CREE LEDs, a well known and recognised brand when talking about LEDs. Incorporating a 316 stainless steel fascia, tempered glass suitable for drive over, aluminium cast body with integral heat transfer system and a special polyester powder coated finish for added durability. A super slim mounting depth with matching polycarbonate housing for concrete installations. Integral LED driver for direct 240VAC connection.

The FUSION-2 is the perfect luminaire for up-lighting exterior facades, feature walls, columns and trees in commercial spaces. Areas of application include parkland landscaping, shopping centres, commercial buildings and the like.





IP65 

SPECIFICATION FEATURES

Power: 24 x 1W CREE LED
Beam Angle: 40°
Colour Range: White and Warm White LED
Materials: 316 stainless steel front fascia
Glass: Tempered Lens
Size: Ø248mm x 55mm
IP Rated: IP65
Lifetime: 50 000 hours
Warranty: 3 years
Impact Resistant: IK10
Drive Over: 2000KGs
Driver: Integral LED driver 240V AC input

PRODUCT CODES

Product code: EV-FUSION-2-W
Order code: 21830
Colour:  White LED 6400K

Product code: EV-FUSION-2-WW
Order code: 21831
Colour:  Warm White LED 3200K

DIAGRAMS / ADDITIONAL

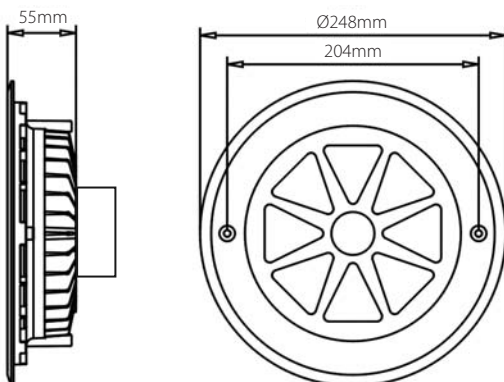

Polycarbonate Housing

