

EV-DEEP-90

deepset downlight

Technical data sheet



DESCRIPTION

The NEW DEEP range of LED down lights are designed for retro fit or new installations. Using a contemporary satin white deepset fixed frame this downlight complements most modern installations.

The DEEP incorporates the latest Sharp COB (Chip on board) which is then matched with a specifically designed heat sink to disburse heat from the LED. All this is then perfectly matched with a fully mains dimmable LED driver complete with a flex and plug for easy installation.



SPECIFICATION FEATURES

- Wattage:** 13W + driver
- LED:** 13W Sharp LED lamp
- Colour/lm:** warm white (3000K) 1045lm, white (5000K) 1095lm
- Efficacy:** warm white 69.7lm/W, white 73lm/W
- Light quality (CRI):** >83
- Beam angle:** 60°
- IP rating:** IP20
- Lifetime:** 50 000hrs
- Input Voltage:** 100-265V AC
- Gimble:** ±15°
- Dimmable:** Yes, on most dimmers (including C-Bus)
- Adaptor ring:** yes
- Operating Temp:** -20° to 65°
- IES Files:** Upon request
- Replacement Warranty:** 3 Years

Product code: EV-DEEP-90-W-WW
Order code: 20552
Colour: Satin White - Warm White 3000K

Product code: EV-DEEP-90-W-W
Order code: 20553
Colour: Satin White - White 5000K

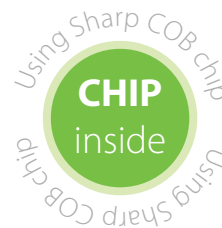

DIAGRAMS

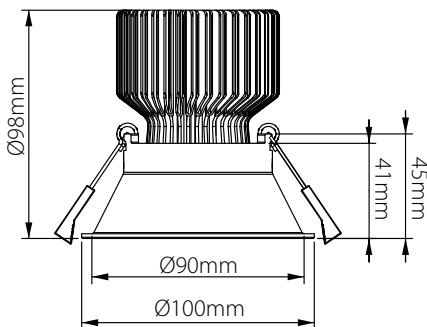

Cutout: Ø90mm

