

EVSHINE-A-S

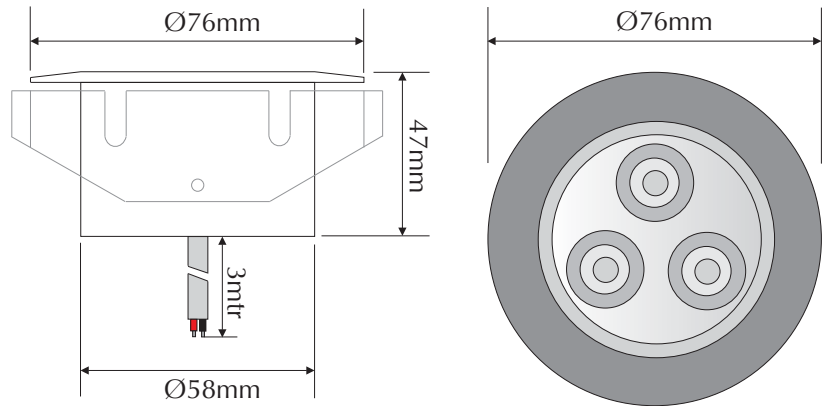

Order Code: **21413**

Product Code: **EVSHINE-A-S**

Colour: **Amber** ■

Description: A smart, elegant and contemporary in-ground up-light. The SHINE is designed for many applications including gardens, decks, hotel lobbies, night clubs etc. The SHINE in-ground up-light packs a lot of punch for its small size and the secret lies in the high power Cree LEDs. Made from 316 stainless steel and with a IP68 rating. The shine is a must for any high end application.

Data: The SHINE in-ground light is made from imported 316 stainless steel, tempered glass, bevel edge design, 20° beam angle, 3 x 1W Cree LED, Amber colour LED, IP68 rated, 12/24V DC, 3mtrs rubberised cable, rated at 50,000 hrs.

Size:

Overall height:	47mm
Overall diameter:	58mm
Front face diameter:	76mm

Cutout: 65mm

Requires: Constant Voltage 12-24V DC LED driver located in the power supply section of the catalogue. Optional mounting tube if required.

316 stainless steel

Amber colour

20° beam angle

12/24V DC input

3W output

Cree LED

IP68 rated

Parallel wiring

50,000 hrs rated

Domus Lighting

29-31 Richland Street Kingsgrove NSW 2208

Phone: (02) 9554 9600 | Fax: (02) 9554 9433 | Email: sales@domuslighting.com