

# EVPL200NW

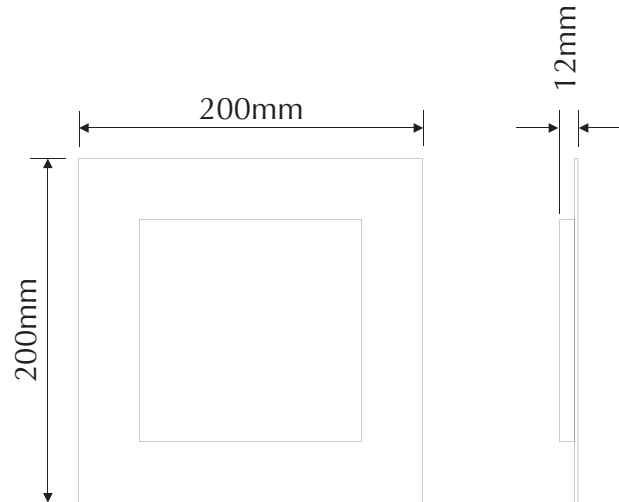
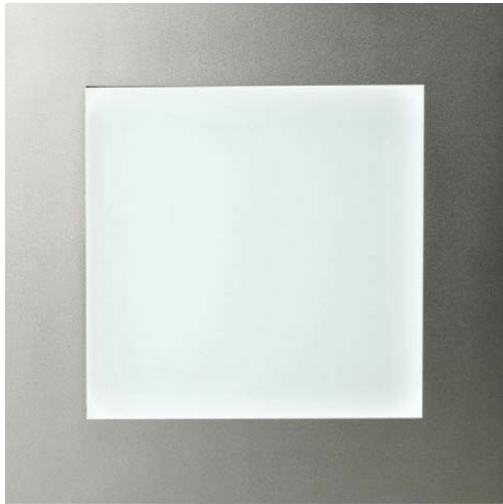

Order Code: **19301**

Product Code: **EVPL200NW**

Colour: **Neutral White**  4000K

Description: Anti glare LED side light panel, LCD TFT backlight technology, 3D V-Cut lighting guide panel, Anodised aluminium frame, satin opal diffuser.

Data: High efficiency SMD LED, satin opal diffuser, 350lm output, approx 115 lux @ 1mtr, colour rendering index greater than 82, weight @ 0.5kgs, average life greater than 50,000 hrs, 9W power consumption, supplied with SMPS 12V DC power supply.

Specification: Panel light to be recessed complete with spring clips.

Frame Size: (L) 200mm x (W) 200mm x (H) 12mm

Panel Size: (L) 160mm x (W) 160mm

Cutout Size: (L) 175mm x (H) 160mm

Neutral White  
4000K

Anti Glare  
Opal diffuser

Approx  
115 lux

350  
Lumens

9W total  
power output

**Domus Lighting**

29-31 Richland Street Kingsgrove NSW 2208

Phone: (02) 9554 9600 | Fax: (02) 9554 9433 | Email: [sales@domuslighting.com](mailto:sales@domuslighting.com)