

# EVPL101NW

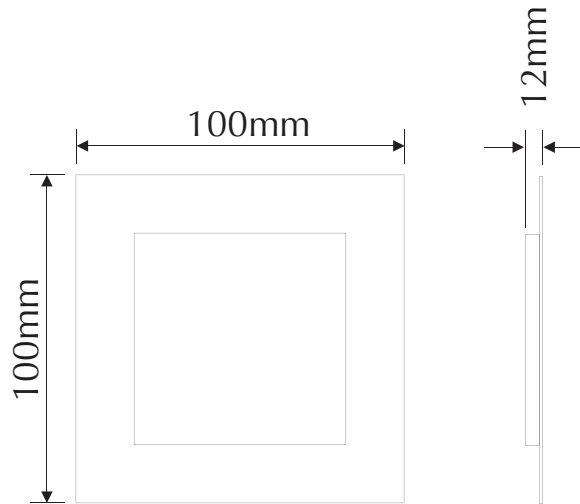
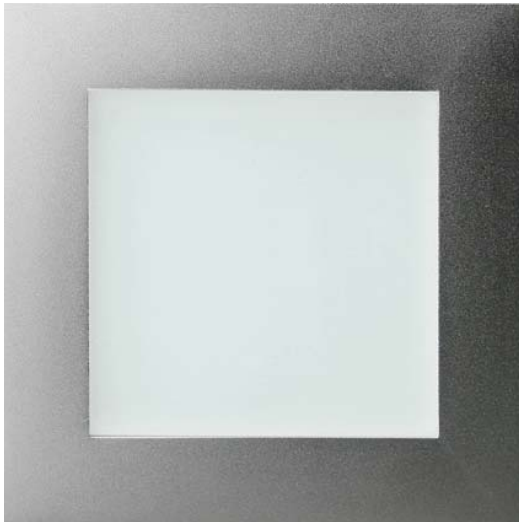

Order Code: **19298**

Product Code: **EVPL101NW**

Colour: **Neutral White**  4000K

Description: Anti glare LED side light panel, LCD TFT backlight technology, 3D V-Cut lighting guide panel, Anodised aluminium frame, satin opal diffuser.

Data: High efficiency SMD LED, satin opal diffuser, 80lm output, approx 40 lux @ 1mtr, colour rendering index greater than 82, weight @ 0.3kgs, average life greater than 50,000 hrs, 2W power consumption, supplied with SMPS 12V DC power supply.

Specification: Panel light to be recessed complete with spring clips.

Frame Size: (L) 100mm x (W) 100mm x (H) 12mm

Panel Size: (L) 90mm x (W) 90mm

Cutout Size: (L) 85mm x (H) 85mm

240V AC  
input

Neutral White  
4000K

Anti Glare  
Opal diffuser

Approx  
40 lux

80  
Lumens

2W total  
power output

**Domus Lighting**

29-31 Richland Street Kingsgrove NSW 2208

Phone: (02) 9554 9600 | Fax: (02) 9554 9433 | Email: [sales@domuslighting.com](mailto:sales@domuslighting.com)