

# EVPD309

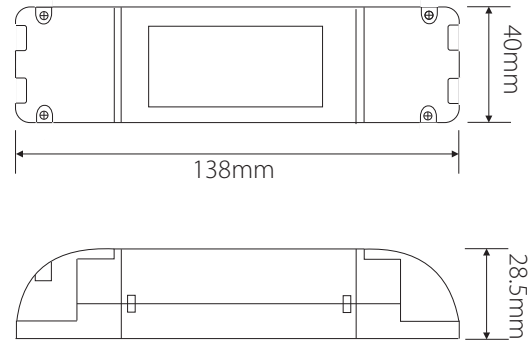

Order Code: **20205**

Product Code: **EVPD309**

Description: Constant Current LED driver for use on LED Power Puk lamps, LED wall washers, inground uplighters and much more.

Data: Insulation: Class II, no earth required, Supply Voltage: 190V-260V AC 50/60Hz (universal input), Supply Current: 0.70A max, Output Voltage: 3V-36V DC SELV (Safety Extra Low Voltage), Min-Max loading: 3-21W 700mA, Start delay: approx 0.5 seconds, Storage temperature: -20°C - +50°C, Ingress protection: IP20.

Features: Secondary side short circuit protection, thermal overload protection, thermal fuse to ensure safe failure if in areas of excessive temperatures, radio interference suppression in accordance with EN55015, safety and performance in accordance with EN61046, EMC immunity in accordance with EN61547, three year replacement guarantee.

Size: (L) 138mm x (W) 40mm x (H) 28.5mm

