

EV PANEL-EXTRUSION

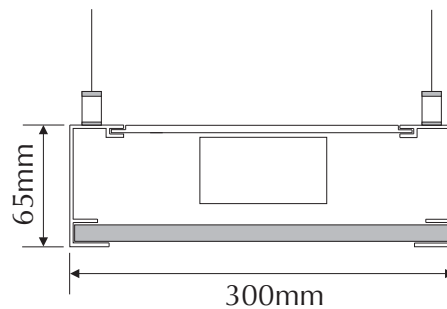
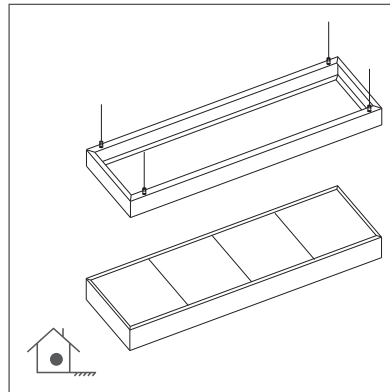

Order Code: **19328**

Product Code: **EV PANEL-EXTRUSION**

Colour: Clear Anodised

Description: Domus Lighting has designed and developed a unique panel mounting system, that allows our range of high output LED panels to be mounted in a multitude of different configurations, including surface mounting and wire suspension. This unique system may be configured to suit our range of panels from 303, 306, 312 and the 606. The system can also be powder coated into any colour in our in-house powder coating facility.

Specification: Made from high grade 2mm thick aluminium, Clear Anodised finish.

Additional: Please contact our sales dept for more detailed information regarding system configurations.