

EVLASER-A-S

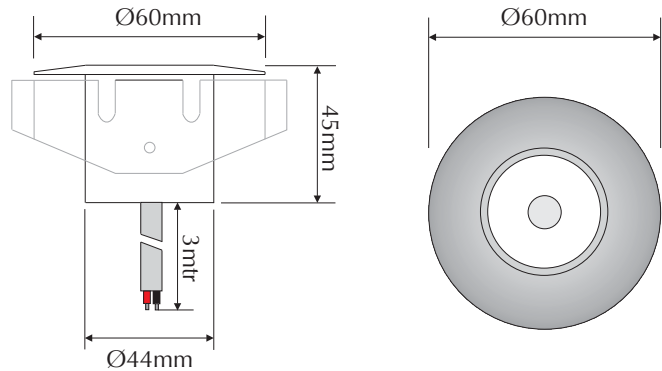

Order Code: **21340**

Product Code: **EVLASER-A-S**

Colour: **Amber** ■

Description: A smart discrete and fully functional mini in-ground/path light. The LASER LED in-ground/path light is a tough and robust luminaire and is designed for all discrete lighting effects. With a IP68 rating and the unique Bevel edge design the Laser is sure to please.

Data: The LASER in-ground/path light is made from imported 316 stainless steel, unique bevel edge design, toughened glass, 1x 1W Cree LED used, 12° beam angle, Amber colour LED, IP68 rated, 12/24V DC, 3mtrs rubberised cable. Rated at 50,000 hrs.

Size:

Overall height:	45mm
Overall diameter:	44mm
Front face diameter:	60mm

Cutout: 50mm

Requires: Constant Voltage 12-24V DC LED driver located in the power supply section of the catalogue. Optional mounting tube if required.



Domus Lighting

29-31 Richland Street Kingsgrove NSW 2208

Phone: (02) 9554 9600 | Fax: (02) 9554 9433 | Email: sales@domuslighting.com