

# EVHALO-500-W

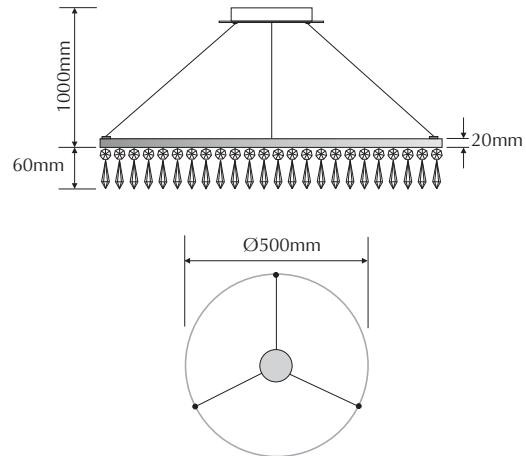
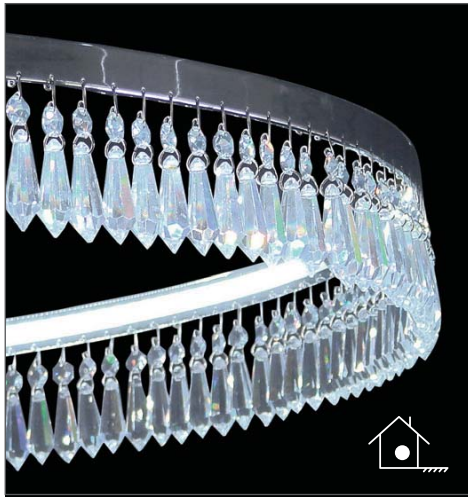

Order Code: **19622**

Product Code: **EVHALO-500-W**

Colour: **White**  6400K

Description: The HALO is a contemporary hand made luminaire. With its high output LED lighting, the sparkle of the Swarovski Strass crystal and the elegant seamless lines of the frame, the HALO gives the owner a striking visual effect.

Data: The HALO 500 is hand made from solid brass and is polish chromed plated, stainless steel wire suspensions, Swarovski Strass crystal, high output LED lighting, White 6400K , 25W total power, integral Constant Voltage LED driver, 240V AC mains input.

Size: Ring: (Ø) 500mm x (H) 20mm  
Suspension: (L) 1000mm

Additional: If dimming is required please call our staff for advice.

High power  
LED

Swarovski  
Strass crystal

White  
6400K

Integral power  
supply

25W total power  
consumption

**Domus Lighting**

29-31 Richland Street Kingsgrove NSW 2208

Phone: (02) 9554 9600 | Fax: (02) 9554 9433 | Email: sales@domuslighting.com