

EV3170

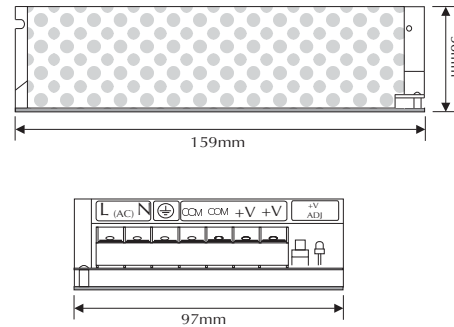

Order Code: **20143**

Product Code: **EV3170**

Description: Constant Voltage LED driver for use on LED MR16 lamps, LED strip lighting, in-ground uplighters and much more.

Data: Output Voltage: 12V DC 60W, Tolerance: 10% ±, Ripple and noise: 120mV Output Current: 5A, Efficiency: 76%, Input frequency: 47-63Hz, Cold start inrush Current: 60A.

Features: Secondary side short circuit protection, thermal overload protection, thermal fuse to ensure safe failure if in areas of excessive temperatures, radio interference suppression in accordance with EN55015, safety and performance in accordance with EN61046, EMC immunity in accordance with EN61547, two year replacement guarantee.

Size: (L) 159mm x (W) 97mm x (H) 38mm

Requires: To be placed in an approved insulated enclosure due to power supply having exposed mains Voltage terminals.

