

EV-DLK13-WW

The NEW DLK-13 range of LED down lights are designed for retro fit or new installations. This is the perfect one to one replacement for traditional halogen lamps.

Using a contemporary satin white adjustable frame with a special adaptor ring makes this down light fit into cutouts as small as Ø80mm through to Ø90mm. The DLK incorporates the latest Sharp COB (Chip on board) which is then matched with a specifically designed heat sink to disperse heat from the LED.

All this is then matched perfectly with a fully mains dimmable LED driver complete with a flex and plug for easy installation.

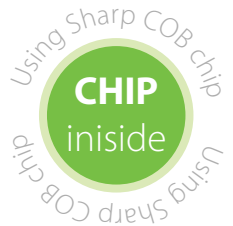

3 Year Replacement Warranty

Product Specifications:

| | |
|----------------------|--|
| Wattage: | 13W + Driver |
| LED: | 13W DLK LED lamp |
| Colour / lm: | Warm white (3000K) 1045lm |
| Efficacy: | Warm white 69.7lm/W |
| Light quality (CRI): | >83 |
| Beam angle: | 60° |
| IP rating: | IP20 |
| Lifetime: | 50 000hrs |
| Input Voltage: | 100-265V AC |
| Gimble: | ±15° |
| Dimmable: | Yes, on most dimmers (including C-Bus) |
| Adaptor ring: | yes (to suit 90mm hole) |
| Operating Temp: | -20° to 65° |
| IES Files: | Upon request |

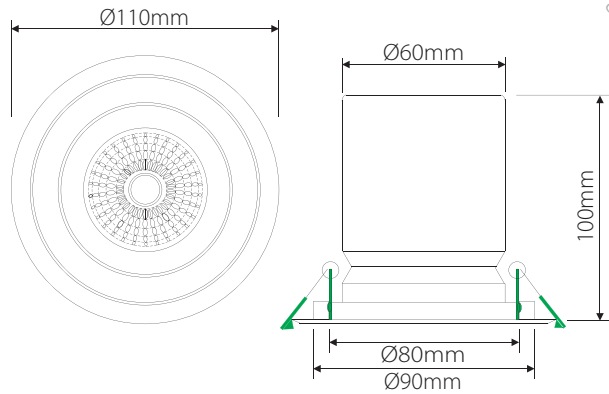

Product Code: **EV-DLK13-WW** | Order Code: **20500**



Warm White 3000K

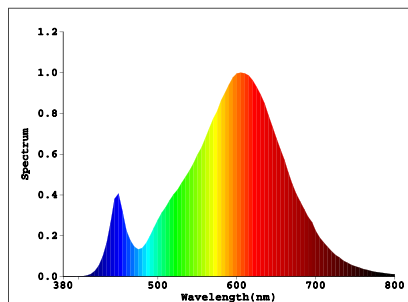

Domus Lighting

29-31 Richland Street Kingsgrove NSW 2208

Phone: (02) 9554 9600 | Fax: (02) 9554 9433 | Email: sales@domuslighting.com

Quality
ISO 9001
SAI GLOBAL

EV-DLK13-WW

Luminous Intensity Distribution Diagram

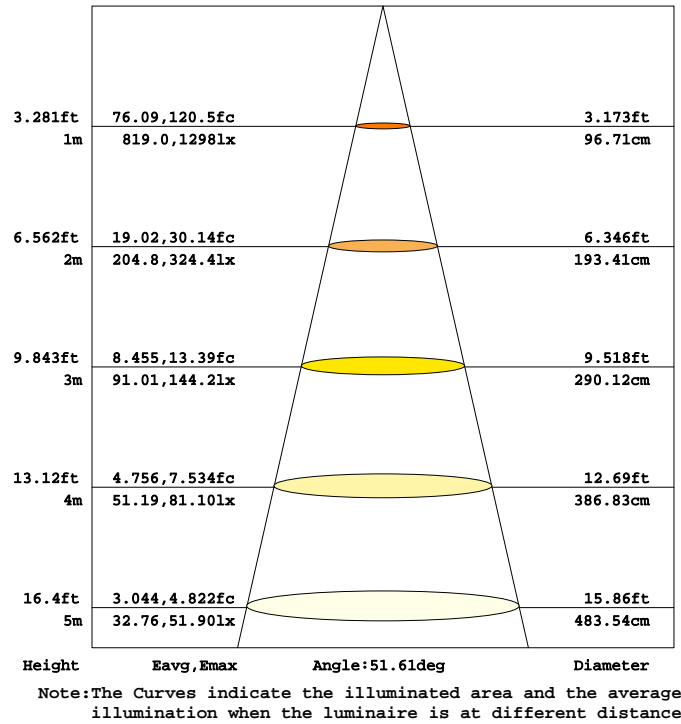
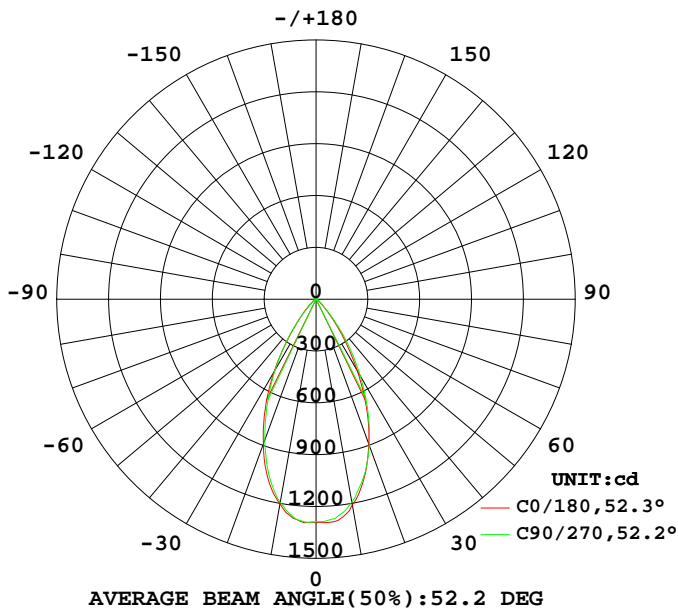

DIALux Simulation

Dimensions: Length 6M x Width 4M x Height 2.4M

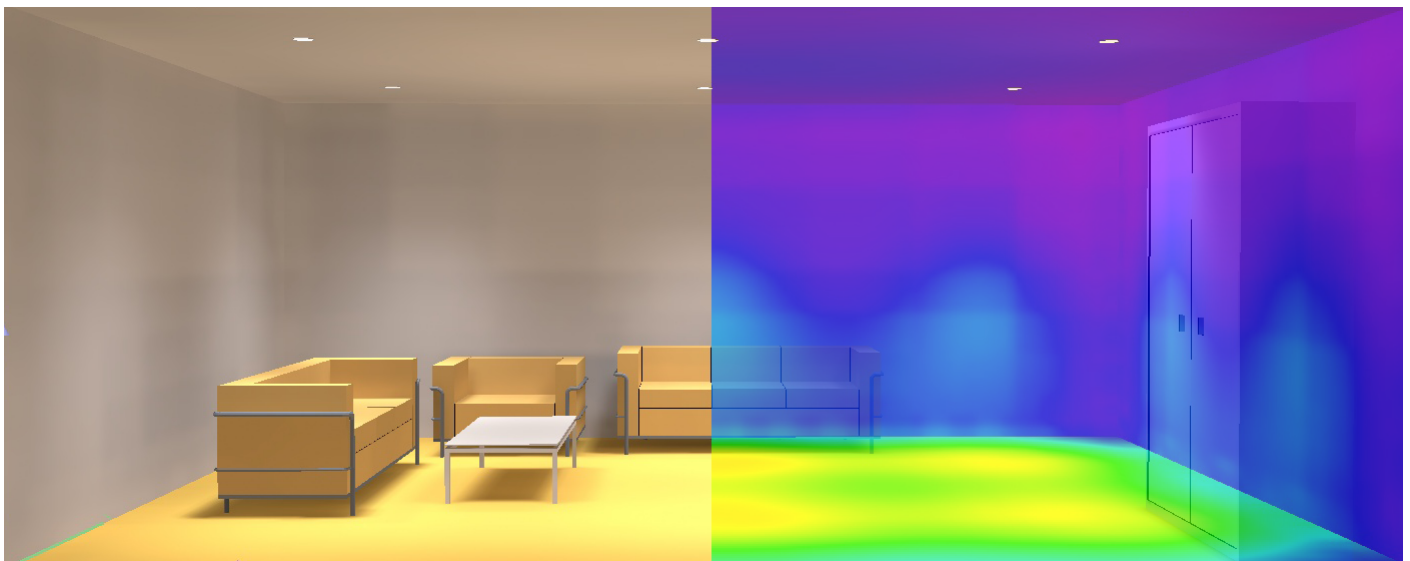

Domus Lighting

29-31 Richland Street Kingsgrove NSW 2208

Phone: (02) 9554 9600 | Fax: (02) 9554 9433 | Email: sales@domuslighting.com