

EV-DLK10-SLR-W

The NEW DLK-10 range of LED down lights are designed for retro fit or new installations.

Using a contemporary silver adjustable frame with a special adaptor ring makes the down light fit into cutouts as small as Ø70mm through to Ø90mm cutouts.

The DLK incorporates the latest SHARP COB (Chip on board) which is then matched with a specifically designed heat sink to disburse heat from the LED. All this is then perfectly matched with a fully mains dimmable LED driver complete with a flex and plug for easy installation.



Using Sharp COB chip
CHIP
inside
Using Sharp COB chip

3 Year Replacement Warranty

Product Specifications:

Wattage:	10W + Driver
LED:	10W DLK LED lamp
Colour / lm:	White (5000K) 780lm
Efficacy:	White 69lm/W
Light quality (CRI):	>83
Beam angle:	60°
IP rating:	IP20
Lifetime:	50 000hrs
Input Voltage:	100-265V AC
Gimble:	±15°
Dimmable:	Yes, on most dimmers (including C-Bus)
Adaptor ring:	yes
Operating Temp:	-20° to 65°
IES Files:	Upon request

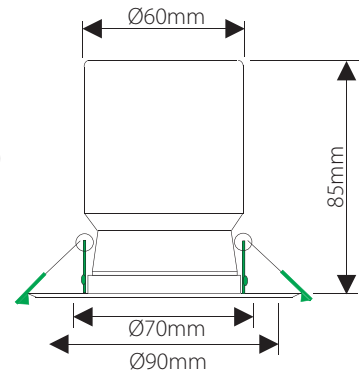
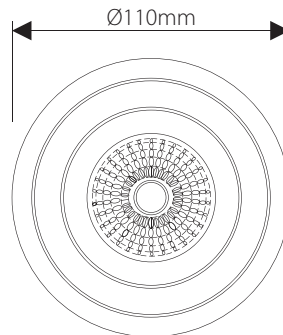

Product Code: **EV-DLK10-SLR-W** | Order Code: **20499**



White 5000K

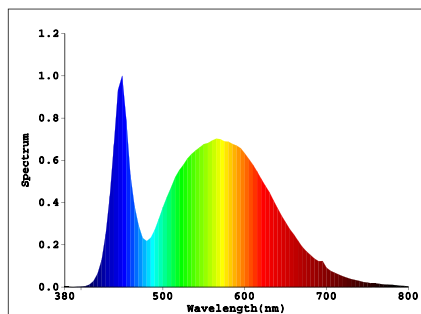

Domus Lighting

29-31 Richland Street Kingsgrove NSW 2208

Phone: (02) 9554 9600 | Fax: (02) 9554 9433 | Email: sales@domuslighting.com

Quality
ISO 9001
SAI GLOBAL

EV-DLK10-SLR-W

Luminous Intensity Distribution Diagram

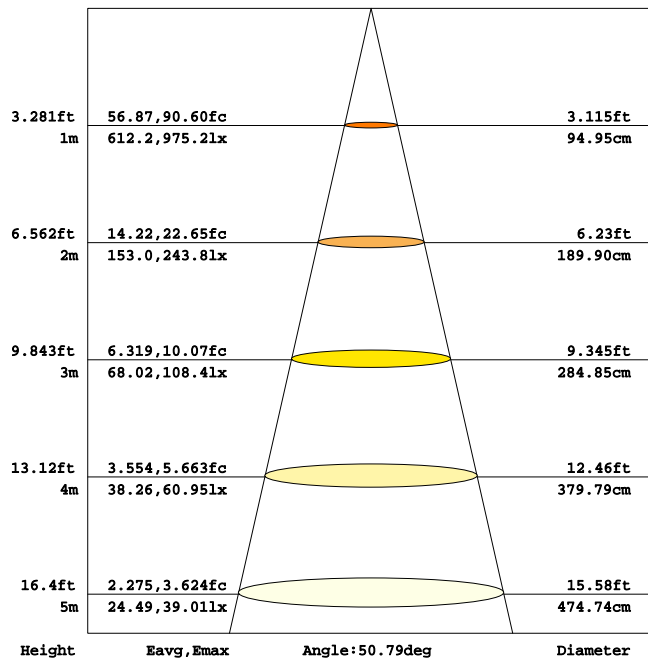
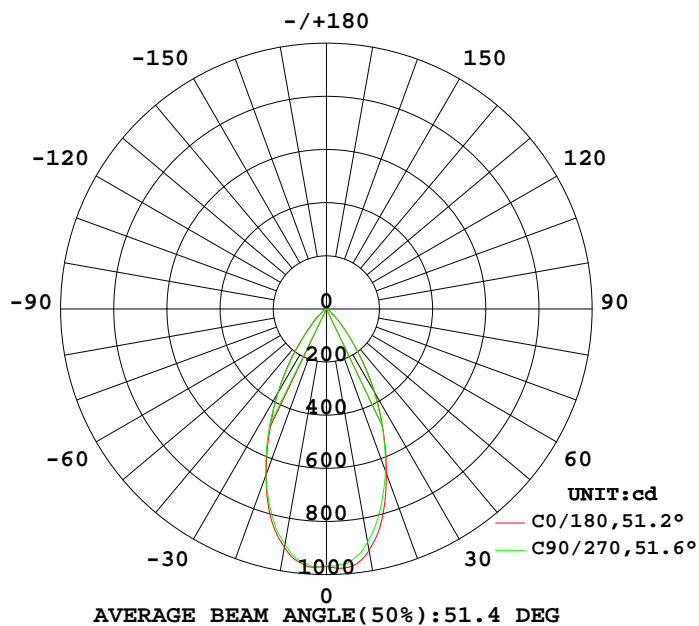

Note: The Curves indicate the illuminated area and the average illumination when the luminaire is at different distance.

DIALux Simulation

Dimensions:
 Width 4M
 Length 4M
 Height 2.4M

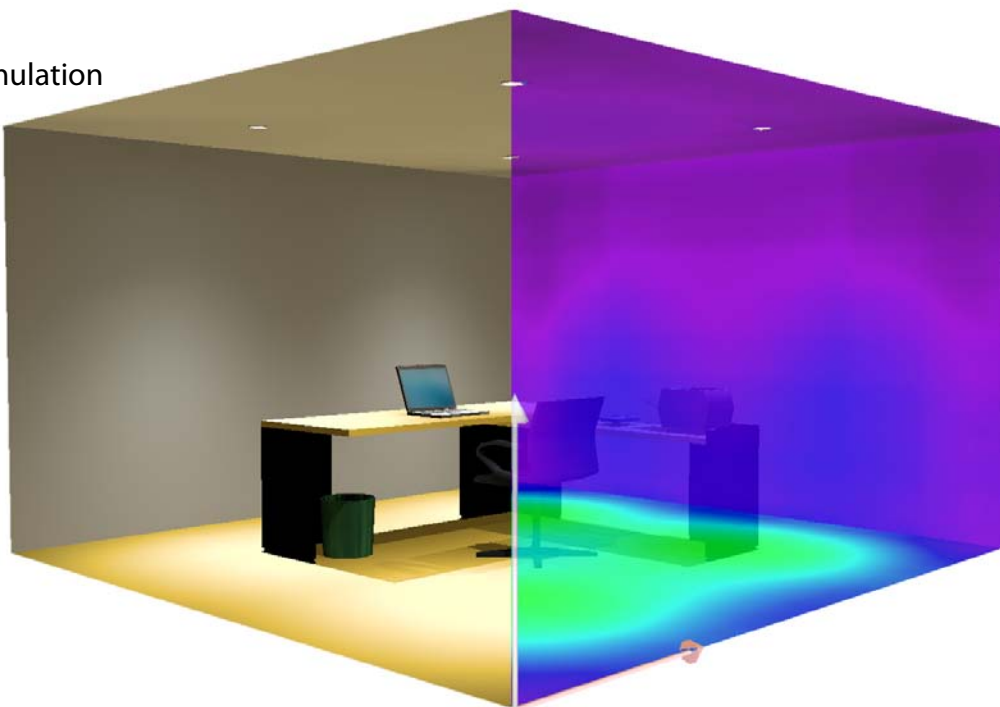

Domus Lighting

29-31 Richland Street Kingsgrove NSW 2208

Phone: (02) 9554 9600 | Fax: (02) 9554 9433 | Email: sales@domuslighting.com