

EV-XWAVE-W

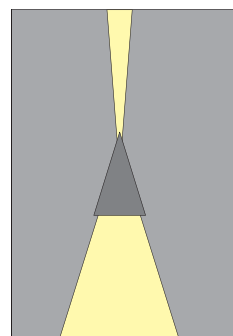
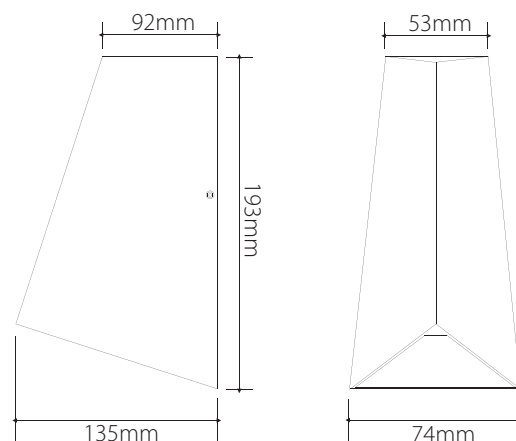

Order Code: 19463

Product Code: EV-XWAVE-W

Description: A smart and very contemporary wall mounted light. With its clean lines and minimal look makes this a must for any interior or exterior application.

Data: Die cast aluminium body, special metalware treatment (Chromate), custom silver colour polyester powder coated finish, 2 x 4W Citizen LED lamps, white colour 6000K, 290lm output, CRI 85%, 20° up 20° down beam angle, built-in LED driver (BID). IP54 rating, 240VAC input voltage.

Fitting Size: (WT) 53mm x (L) 193mm x (WB) 74mm (P) 135mm

Additional: The above wall light is non dimmable.

Domus Lighting

29-31 Richland Street Kingsgrove NSW 2208

Phone: (02) 9554 9600 | Fax: (02) 9554 9433 | Email: sales@domuslighting.com

EV-XWAVE-WW

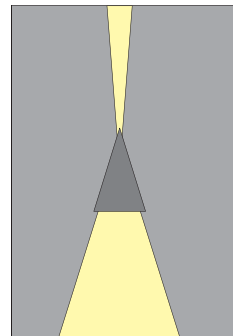
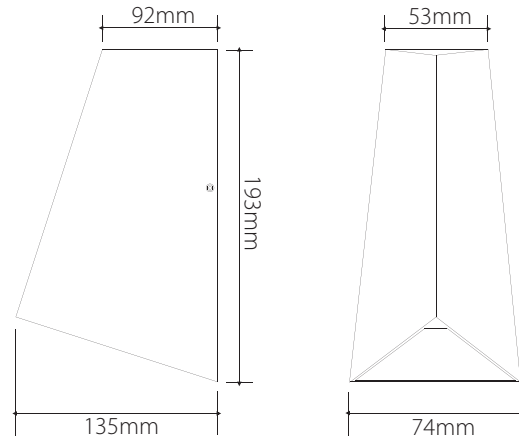

Order Code: 19462

Product Code: EV-XWAVE-WW

Description: A smart and very contemporary wall mounted light. With its clean lines and minimal look makes this a must for any interior or exterior application.

Data: Die cast aluminium body, special metalware treatment (Chromate), custom silver colour polyester powder coated finish, 2 x 4W Citizen LED lamps, warm white colour 3000K, 250lm output, CRI 85%, 20° up 20° down beam angle, built-in LED driver (BID). IP54 rating, 240VAC input voltage.

Fitting Size: (WT) 53mm x (L) 193mm x (WB) 74mm (P) 135mm

Additional: The above wall light is non dimmable.

Domus Lighting

29-31 Richland Street Kingsgrove NSW 2208

Phone: (02) 9554 9600 | Fax: (02) 9554 9433 | Email: sales@domuslighting.com