

# EVPL606WW

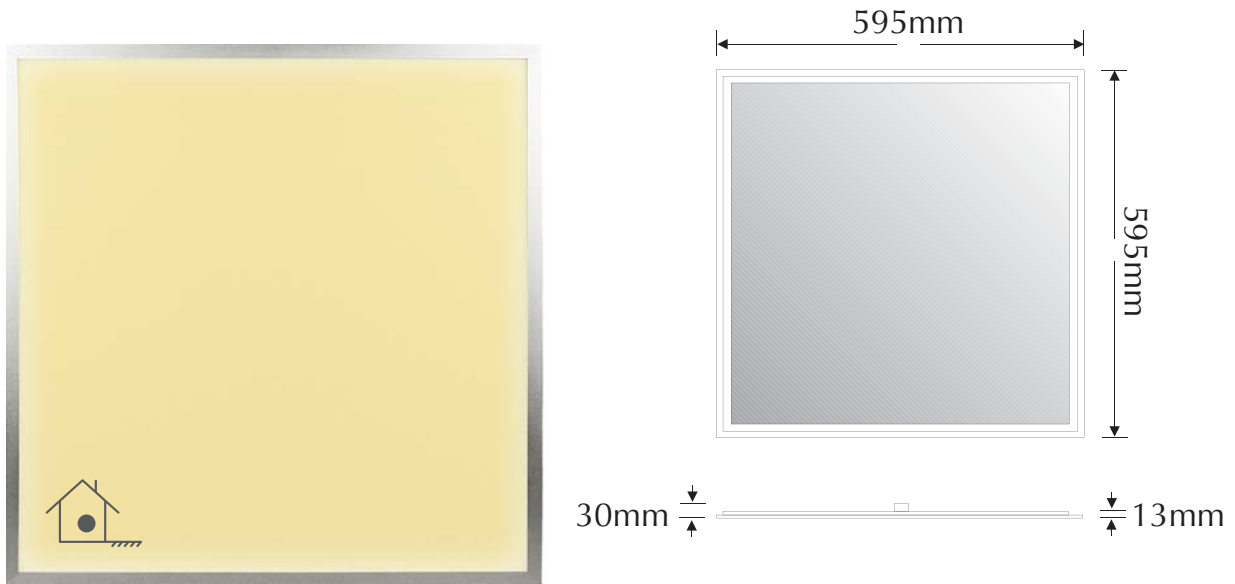

Order Code: **19314**

Product Code: **EVPL606WW**

Colour: **Warm White**  3200K

Description: Anti glare LED side light panel, LCD TFT backlight technology, 3D V-Cut lighting guide panel, Anodised aluminium frame, satin opal diffuser.

Data: High efficiency SMD LED, satin opal diffuser, 1800lm output, approx 400 lux @ 1mtr, colour rendering index greater than 82, weight @ 5kgs, average life greater than 50,000 hrs, 38W power consumption, supplied with 12V DC power supply.

Specification: Panel light can be recessed into standard grid ceiling or via optional plaster trim kit for plaster board ceilings or via optional wire suspended or surface mounted kit.

Frame Size: (L) 595mm x (W) 595mm x (H) 13mm

Panel Size: (L) 565mm x (W) 565mm

Warm White  
3200K

Anti Glare  
Opal diffuser

Approx  
400 lux

1800  
Lumens

38W total  
power output

**Domus Lighting**

29-31 Richland Street Kingsgrove NSW 2208

Phone: (02) 9554 9600 | Fax: (02) 9554 9433 | Email: sales@domuslighting.com

# EVPL606NW

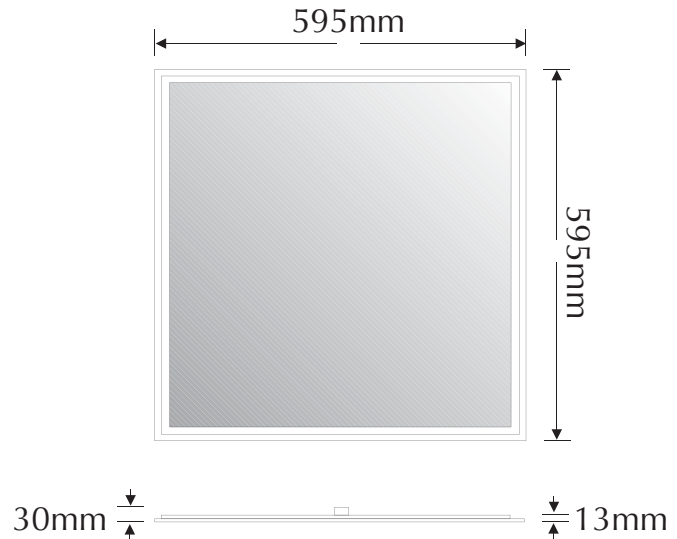

Order Code: **19313**

Product Code: **EVPL606NW**

Colour: **Neutral White**  4000K

Description: Anti glare LED side light panel, LCD TFT backlight technology, 3D V-Cut lighting guide panel, Anodised aluminium frame, satin opal diffuser.

Data: High efficiency SMD LED, satin opal diffuser, 1900lm output, approx 550 lux @ 1mtr, colour rendering index greater than 82, weight @ 5kgs, average life greater than 50,000 hrs, 38W power consumption, supplied with 12V DC power supply.

Specification: Panel light can be recessed into standard grid ceiling or via optional plaster trim kit for plaster board ceilings or via optional wire suspended or surface mounted kit.

Frame Size: (L) 595mm x (W) 595mm x (H) 13mm

Panel Size: (L) 565mm x (W) 565mm

Neutral White  
4000K

Anti Glare  
Opal diffuser

Approx  
550 lux

1900  
Lumens

38W total  
power output

**Domus Lighting**

29-31 Richland Street Kingsgrove NSW 2208

Phone: (02) 9554 9600 | Fax: (02) 9554 9433 | Email: sales@domuslighting.com

# EVPL606W

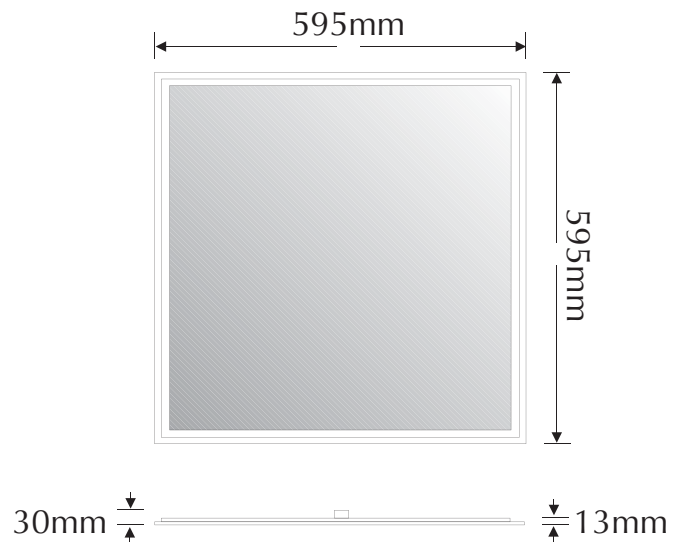

Order Code: **19312**

Product Code: **EVPL606W**

Colour: **White**  6500K

Description: Anti glare LED side light panel, LCD TFT backlight technology, 3D V-Cut lighting guide panel, Anodised aluminium frame, satin opal diffuser.

Data: High efficiency SMD LED, satin opal diffuser, 2000lm output, approx 600 lux @ 1mtr, colour rendering index greater than 82, weight @ 5kgs, average life greater than 50,000 hrs, 38W power consumption, supplied with 12V DC power supply.

Specification: Panel light can be recessed into standard grid ceiling or via optional plaster trim kit for plaster board ceilings or via optional wire suspended or surface mounted kit.

Frame Size: (L) 595mm x (W) 595mm x (H) 13mm

Panel Size: (L) 565mm x (W) 565mm

White 6500K	Anti Glare Opal diffuser	Approx 600 lux	2000 Lumens	38W total power output
----------------	-----------------------------	-------------------	----------------	---------------------------

**Domus Lighting**

29-31 Richland Street Kingsgrove NSW 2208

Phone: (02) 9554 9600 | Fax: (02) 9554 9433 | Email: sales@domuslighting.com