

EV-PL101-WWW

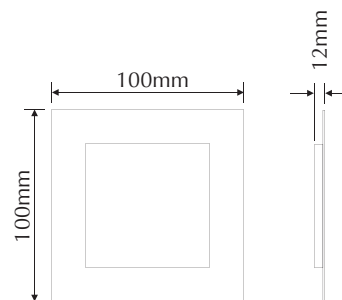
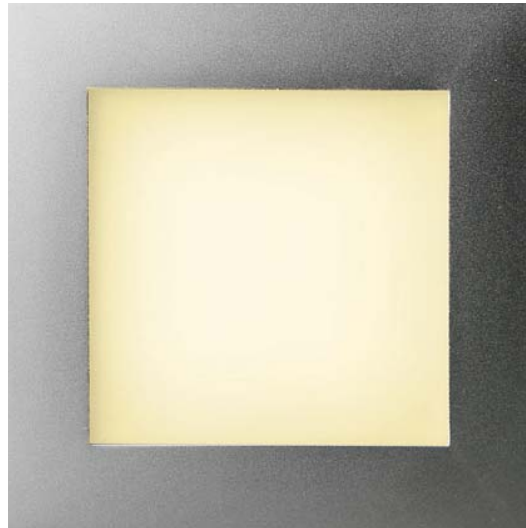

Order Code: **19297**

Product Code: **EV-PL101-WW**

Colour: **Warm White**  3200K

Description: Anti glare LED side light panel, LCD TFT backlight technology, 3D V-Cut lighting guide panel, anodised aluminium frame, satin opal diffuser.

Data: High efficiency SMD LED, satin opal diffuser, 60lm output, approx 35 lux @ 1mtr, colour rendering index greater than 82, weight @ 0.3kgs, average life greater than 50,000 hrs, 2W power consumption, supplied with SMPS 12V DC power supply.

Specification: Panel light to be recessed complete with spring clips.

Frame Size: (L) 100mm x (W) 100mm x (H) 12mm

Panel Size: (L) 90mm x (W) 90mm

Cutout Size: (L) 85mm x (H) 85mm

240V AC
input

Warm White
3200K

Anti Glare
Opal diffuser

Approx
35 lux

60
Lumens

2W total
power output

Domus Lighting

29-31 Richland Street Kingsgrove NSW 2208

Phone: (02) 9554 9600 | Fax: (02) 9554 9433 | Email: sales@domuslighting.com

EV-PL101-W

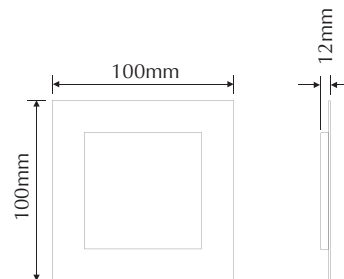

Order Code: **19299**

Product Code: **EV-PL101-W**

Colour: **White** 6500K

Description: Anti glare LED side light panel, LCD TFT backlight technology, 3D V-Cut lighting guide panel, anodised aluminium frame, satin opal diffuser.

Data: High efficiency SMD LED, satin opal diffuser, 100lm output, approx 50 lux @ 1mtr, colour rendering index greater than 82, weight @ 0.3kgs, average life greater than 50,000 hrs, 2W power consumption, supplied with SMPS 12V DC power supply.

Specification: Panel light to be recessed complete with spring clips.

Frame Size: (L) 100mm x (W) 100mm x (H) 12mm

Panel Size: (L) 90mm x (W) 90mm

Cutout Size: (L) 85mm x (H) 85mm

240V AC
input

White
6500K

Anti Glare
Opal diffuser

Approx
50 lux

100
Lumens

2W total
power output

Domus Lighting

29-31 Richland Street Kingsgrove NSW 2208

Phone: (02) 9554 9600 | Fax: (02) 9554 9433 | Email: sales@domuslighting.com

EV-PL101-NW

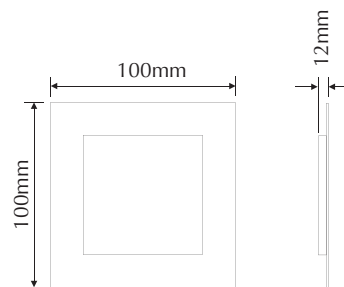
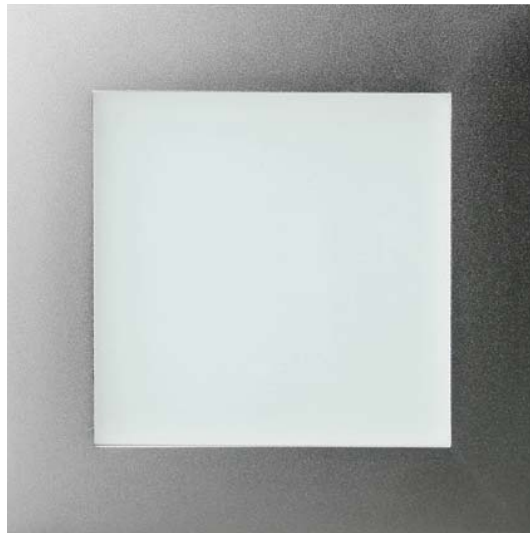

Order Code: **19298**

Product Code: **EV-PL101-NW**

Colour: **Neutral White** 4000K

Description: Anti glare LED side light panel, LCD TFT backlight technology, 3D V-Cut lighting guide panel, anodised aluminium frame, satin opal diffuser.

Data: High efficiency SMD LED, satin opal diffuser, 80lm output, approx 40 lux @ 1mtr, colour rendering index greater than 82, weight @ 0.3kgs, average life greater than 50,000 hrs, 2W power consumption, supplied with SMPS 12V DC power supply.

Specification: Panel light to be recessed complete with spring clips.

Frame Size: (L) 100mm x (W) 100mm x (H) 12mm

Panel Size: (L) 90mm x (W) 90mm

Cutout Size: (L) 85mm x (H) 85mm

240V AC
input

Neutral
White 4000K

Anti Glare
Opal diffuser

Approx
40 lux

80
Lumens

2W total
power output

Domus Lighting

29-31 Richland Street Kingsgrove NSW 2208

Phone: (02) 9554 9600 | Fax: (02) 9554 9433 | Email: sales@domuslighting.com