

SW-762

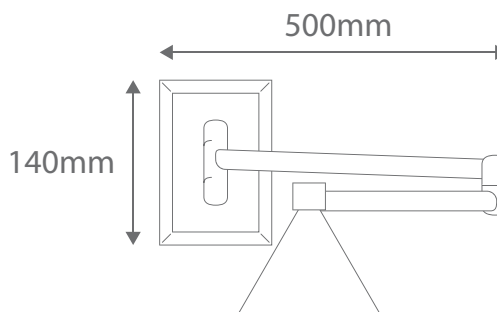

Low Voltage Double Swing Arm (No Switch)

Order Code:	18564	Black	1 x 50W QT12
	18565	Brass	1 x 50W QT12
	18566	Chrome	1 x 50W QT12
	18568	Satin Brass	1 x 50W QT12
	18569	Satin Chrome	1 x 50W QT12
	18570	White	1 x 50W QT12

Dimensions: Width 500mm
Height 140mm



Made in Australia

Requires: Remote transformer and lamp.

LED Option: LED 12V BI-PIN Lamp recommended.
Please refer to Lamps Section.

Product Code: **SW-762**

Spare Glass: **17595** LVG-5705 FRS

Description: Double jointed arm complete with backplate, shade and lamp holder (**no switch**).

Domus Lighting

29-31 Richland Street Kingsgrove NSW 2208

Phone: (02) 9554 9600 | Fax: (02) 9554 9433 | Email: sales@domuslighting.com



Quality
ISO 9001
SAI GLOBAL