

# GU-DRAGONE-4SQ SCH



## Four Light Square

Order Code: **30018** Satin Chrome 4 x 50W GU10

Product Code: **GU-DRAGONE-4SQ SCH**

Description: Four adjustable 240V GU10 Spotlights on a square plate.  
No Transformer required.

Dimensions: Width 280mm  
Height 135mm

Lamp: 4 x 50W GU10

LED Option: LED GU10 Lamp recommended.  
Please refer to Lamps Section.

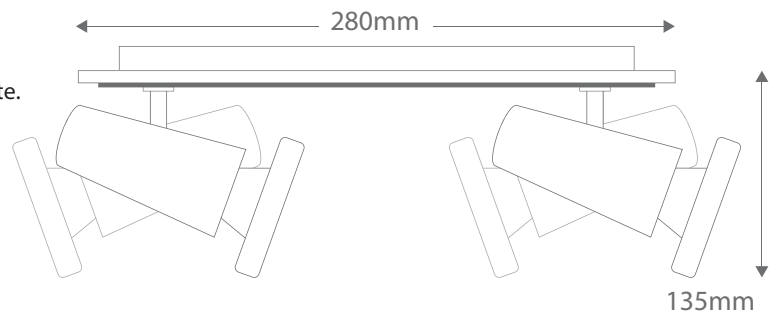

**Domus Lighting**

29-31 Richland Street Kingsgrove NSW 2208

Phone: (02) 9554 9600 | Fax: (02) 9554 9433 | Email: sales@domuslighting.com