

GU-8100/4SQ



Four Light Square

Order Code: **16153** Satin Chrome 4 x 50W GU10

Product Code: **GU-8100/4SQ**

Description: Four adjustable 240V GU10 spotlights on a square base.
No transformer required.

Dimensions: Width 220mm
Height 120mm

Lamp: 4 x 50W GU10

LED Option: LED GU10 Lamp recommended.
Please refer to Lamps Section.

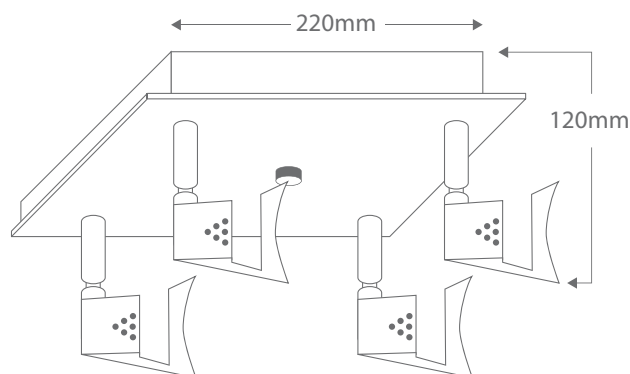

Domus Lighting

29-31 Richland Street Kingsgrove NSW 2208

Phone: (02) 9554 9600 | Fax: (02) 9554 9433 | Email: sales@domuslighting.com