



# LAWSON

## EXTERIOR WALL BRACKET



- 240v
- 60w max
- E27
- E27 CFL
- IP44
- INCLUDED

Traditional styled wall bracket with glass diffuser in architectural grade 304 stainless steel. IP44 weatherproof rated for superior protection against the elements.  
12 Month Warranty.

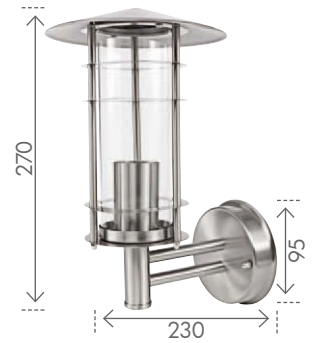

Code:	<b>100431/..</b>
<b>16</b> STAINLESS STEEL (304)	 9 312641 431169 >



# PATTERSON

## EXTERIOR WALL BRACKET WITH SENSOR



- 240v
- 40w max
- G9
- IP44
- Detection: 110° x 6m
- 110°
- Lux Setting
- Time on: 10s to 6m
- Manual override
- INCLUDED

Modern styled halogen wall bracket with glass diffuser in 304 stainless steel. IP44 weatherproof rated for superior protection against the elements.  
Detection: 6m at 110° scan  
Time 'On' : 10 sec to 6 min  
Adjustable Lux Setting with Dusk to Dawn Sensor  
Manual Override Function  
12 Month Warranty.

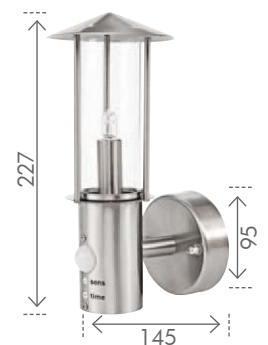

Code:	<b>100430/..</b>
<b>16</b> STAINLESS STEEL (304)	 9 312641 430162 >