

BL-8050

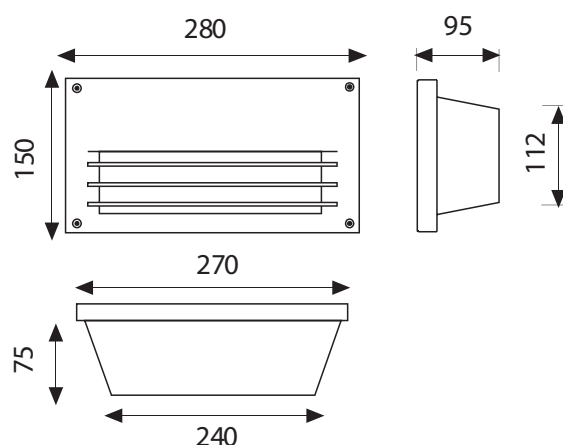

BL-8050.00X

Lamp: A60
Power: 60W
Base: E27

BL-8050.96X

Lamp: TC-D
Power: 18W
Base: G24 d-2

BL-8050.95X

Lamp: TC-D
Power: 26W
Base: G24 d-3

Colours

X=2 White X=9 Anthracite
X=3 Black X=4 Silver

- Recessed wall luminaire
- Die-cast painted aluminium body
- Satin tempered glass or polycarbonate diffuser
- Aluminium reflector
- EPDM gaskets
- Technopolymer wall holder
- Stainless steel screws
- Painting using high resistance to UV and corrosion polyester powders

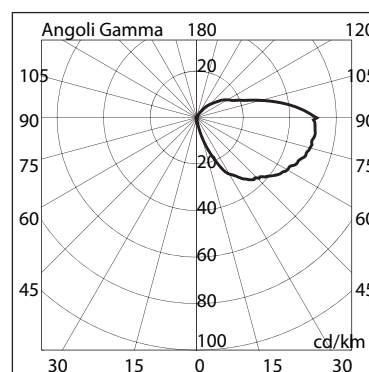

8050 95



Domus Lighting

29-31 Richland Street Kingsgrove NSW 2208

Phone: (02) 9554 9600 | Fax: (02) 9554 9433 | Email: sales@domuslighting.com

