

BL-8024

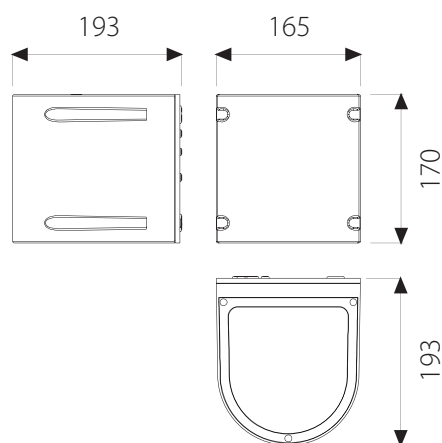

Available Colours:

| | | | | | |
|-----|--|-------|-----|--|------------|
| X=2 | | White | X=9 | | Anthracite |
| X=3 | | Black | X=4 | | Silver |

BL-8024.10X

Lamp: QT32
Power: 100W
Base: E27



- Wall outdoor luminaire with various light band openings constructed
- Painted die-cast aluminium structure
- Tempered glasses or/and lenses
- Aluminium reflector
- Silicon gasket
- Stainless steel screws
- Painting using high resistance to UV and corrosion polyester powders

Domus Lighting

29-31 Richland Street Kingsgrove NSW 2208

Phone: (02) 9554 9600 | Fax: (02) 9554 9433 | Email: sales@domuslighting.com