

BL-8021

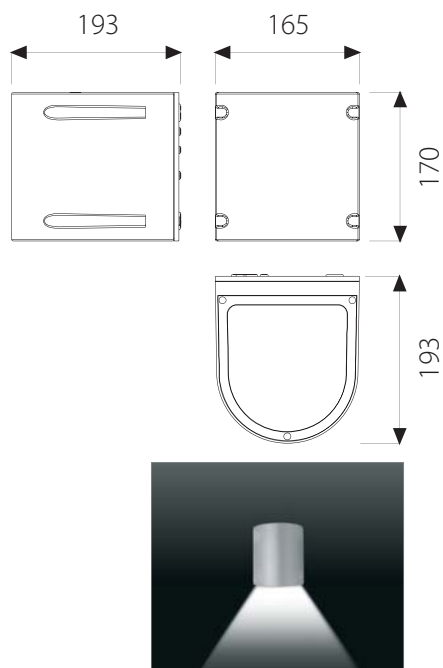

BL-8021.14X

Lamp: A60
Power: 100W
Base: E27

BL-8021.83X

Lamp: TC-T
Power: 26W
Base: GX24 d-3

BL-8021.10X

Lamp: QT32
Power: 100W
Base: E27

Available Colours:

X=2 White X=9 Anthracite
X=3 Black X=4 Silver

- Wall outdoor luminaire with various light band openings constructed
- Painted die-cast aluminium structure
- Tempered glasses or/and lenses
- Aluminium reflector
- Silicon gasket
- Stainless steel screws
- Painting using high resistance to UV and corrosion polyester powders

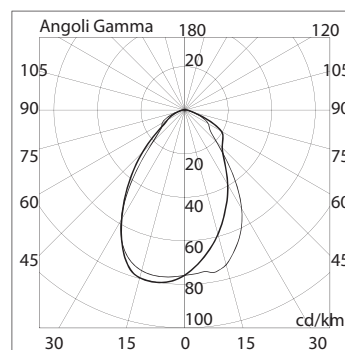

8021 83



Domus Lighting

29-31 Richland Street Kingsgrove NSW 2208

Phone: (02) 9554 9600 | Fax: (02) 9554 9433 | Email: sales@domuslighting.com