

BL-6042

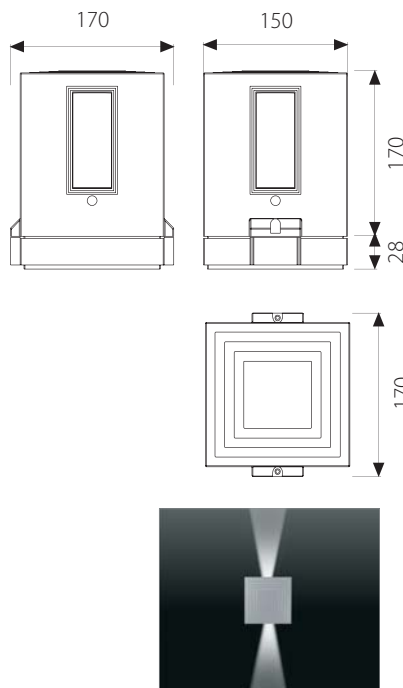

BL-6042.10X
Lamp: QT32
Power: 100W
Base: E27

BL-6042.83X
Lamp: TC-T
Power: 26W
Base: GX24 d-3

Available Colours:

- X=9  Anthracite
- X=4  Silver

- Wall outdoor and indoor luminaire with various light beams
- Painted die-cast aluminium structure
- Tempered glasses or/and lenses
- Aluminium reflector
- Silicon gaskets
- Stainless steel screws
- Painting using high resistance to UV and corrosion polyester powders

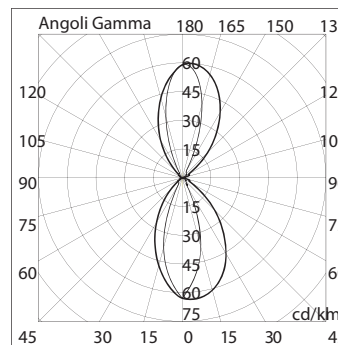

6042 83

