

BL-6022

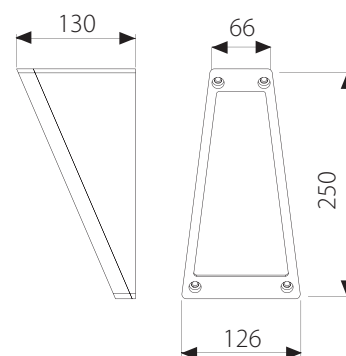
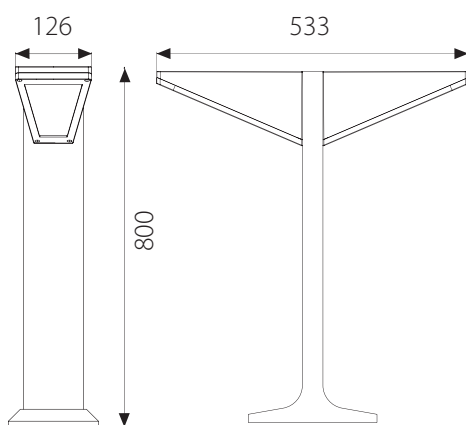

BL-6022.95X
Lamp: TC-DEL
Power: 2 x 26W
Base: G24 q-3

BL-6022.85X
Lamp: HIT-TC
Power: 2 x 20W
Base: G8.5

- Outdoor wall luminaire
- Painted die-cast aluminium head
- Painted extruded aluminium post
- Tempered satin glass diffuser
- Aluminium reflector
- Silicon gaskets
- Stainless steelscrews
- Painting using high resistance to UV and corrosion polyester powders

Available Colours:

X=2 White X=9 Anthracite
X=3 Black X=4 Silver

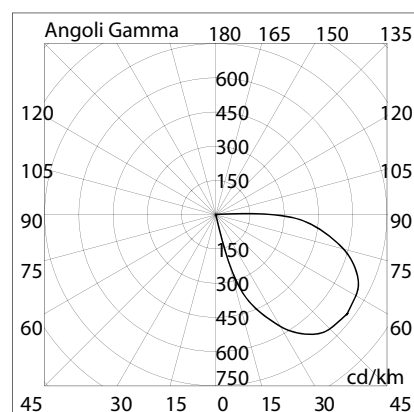

6022 85



Domus Lighting

29-31 Richland Street Kingsgrove NSW 2208

Phone: (02) 9554 9600 | Fax: (02) 9554 9433 | Email: sales@domuslighting.com