

BL-5092

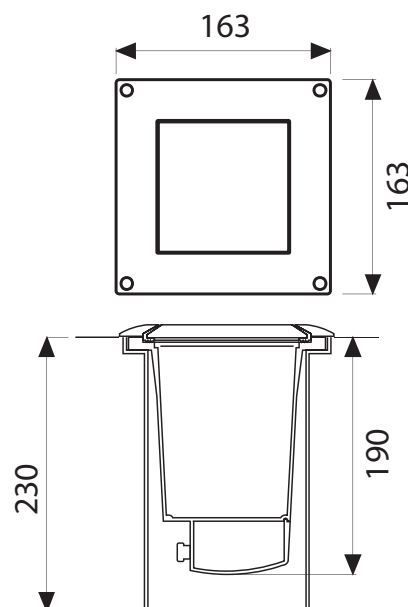

BL-5092.000

Lamp: Q PAR20
Power: 50W
Base: E27

BL-5092.150

Lamp: Q PAR16
Power: 40W
Base: E14

BL-5092.880

Lamp: 1 x White LED
Power: 4.1W
LED: 230lm 6300K

BL-5092.660

Lamp: 3 x White LED
Power: 9W
LED: 500lm 6300K

- Outdoor recessed ground luminaire
- Painted die-cast aluminium structure
- Stainless steel cover
- Transparent glass diffuser
- Aluminium reflector
- Silicon gaskets
- Stainless steel screws
- Technopolymer holder
- Painting using high resistance to UV and corrosion polyester powders

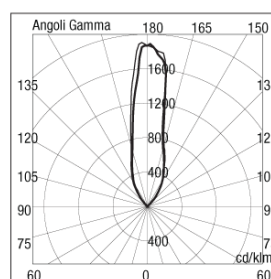

5092 00

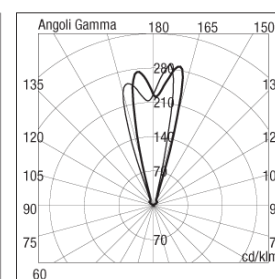

5092 66

