

BL-5070

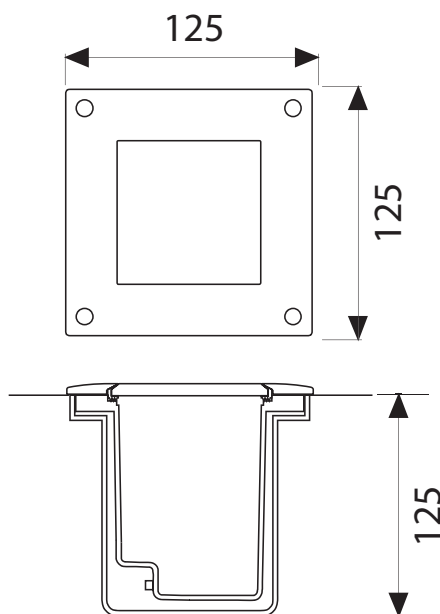

BL-5070.14X	BL-5070.15X	BL-5070.60X
Lamp: QT14	Lamp: Q PAR16	Lamp: T2
Power: 40W	Power: 35W	Power: 6W
Base: G9	Base: GU10	Base: Gx53

BL-5070.68X	BL-5070.88X
Lamp: 60 x White LED	Lamp: 1 x White LED
Power: 4W	Power: 4.1W
Base: Gx53	Base: 230lm 6300K
LED: 260lm 4000K	

Available Colours:

X=2		White	X=4		Silver
X=3		Black	X=9		Anthracite

- Outdoor and indoor wall and recessed ground luminaire
- Painted die-cast aluminium structure
- Die-cast aluminium cover
- Satin glass diffuser
- Aluminium reflector
- Silicon gaskets
- Stainless steel screws
- Technopolymer holder
- Painting using high resistance to UV and corrosion polyester powders

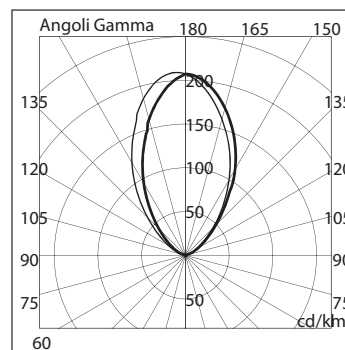

5070 14

