

BL-5025

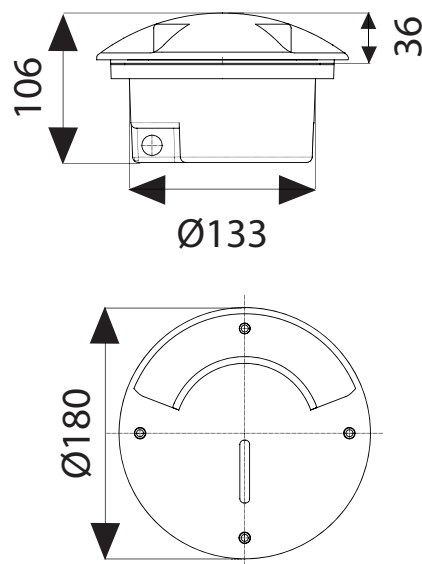

BL-5025.14X
Lamp: QT14
Power: 75W
Base: G9

BL-5025.92X
Lamp: TC-D
Power: 10W
Base: Gx24 d-1

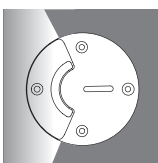

BL-5025.60X
Lamp: T2
Power: 6W
Base: Gx53

BL-5025.68X
Lamp: 60 LED
Power: 4W
Base: Gx53

BL-5025.88X
Lamp: 60 LED
Power: 4.1W
LED: 230lm 6300K

Available Colours:

X=3 Black X=9 Anthracite
X=4 Silver

- Outdoor recessed driveover ground luminaire
- Painted die-cast aluminium body
- Transparent tempered glass diffuser
- Aluminium reflector
- Silicon gasket
- Stainless steel screws
- Polypropylene holder
- Painting using high resistance to UV and corrosion polyester powders

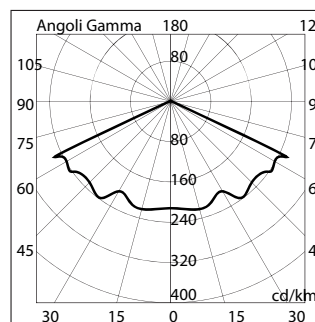

5025 14

