

BL-5016

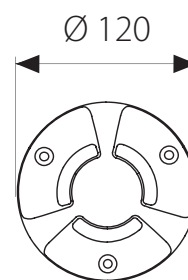

BL-5016.09X
Lamp: QT9
Power: 20W
Base: G4

BL-5016.14X
Lamp: QT14
Power: 25W
Base: G9

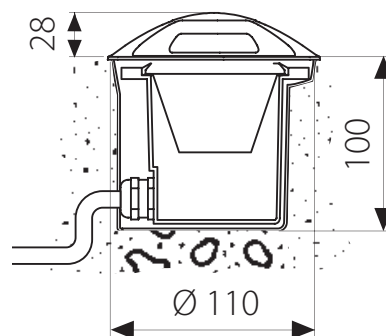
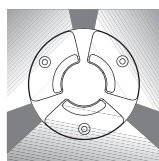

BL-5016.60X
Lamp: T2
Power: 6W
Base: Gx53

BL-5016.16X
Lamp: 12 LED
Power: 6W
LED: 25lm 6000K

BL-5016.88X
Lamp: 1 LED
Power: 4.1W
LED: 230lm 6300K

Available Colours:

X=3 Black X=9 Anthracite
X=4 Silver

- Outdoor recessed wall or driveover ground luminaire
- Painted die-cast aluminium body
- Satin tempered glass diffuser
- Aluminium reflector
- Silicon gasket
- Stainless steel screws
- Technopolymer holder
- Painting using high resistance to UV and corrosion polyester powders

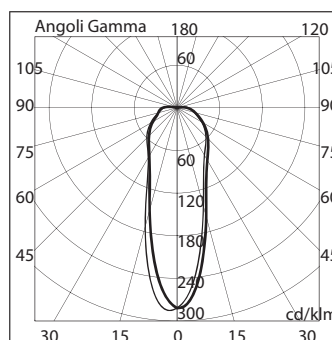

5016 16

