

# BL-5010

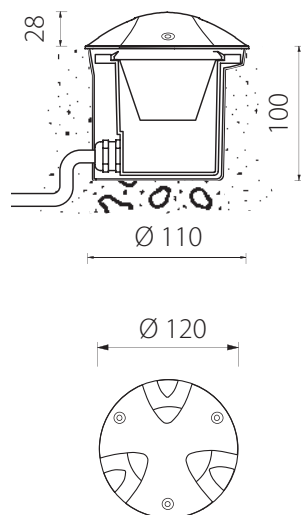



## BL-5010.88X

Lamp: 1 LED  
Power: 4.1W  
LED: 230lm 6300K



### Available Colours:

X=3  Black    X=9  Anthracite  
X=4  Silver

- Outdoor recessed drive-over ground or wall luminaire with LED technology
- Painted die-cast aluminium body
- Satin tempered glass diffuser
- Silicon gaskets
- Stainless steel screws
- Technopolymer holder
- Painted using high resistance to UV and corrosion polyester powders

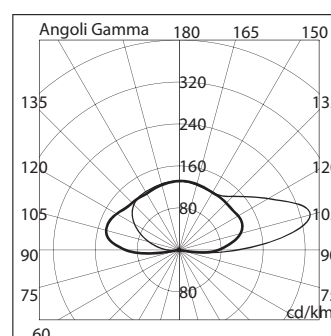

5010 88



**Domus Lighting**

29-31 Richland Street Kingsgrove NSW 2208

Phone: (02) 9554 9600 | Fax: (02) 9554 9433 | Email: sales@domuslighting.com