

# BL-4094

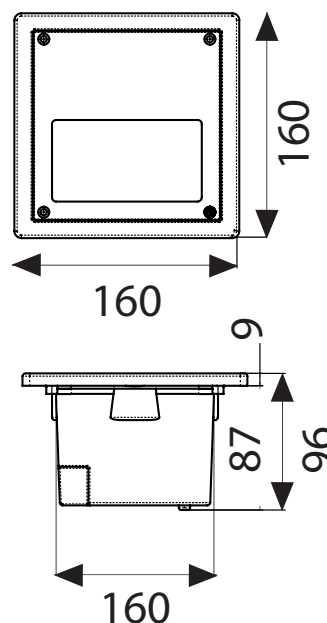

**BL-4094.14X**  
Lamp: QT14  
Power: 75W  
Base: G9

**BL-4094.60X**  
Lamp: T2  
Power: 6W  
Base: GX53

**BL-4094.68X**  
Lamp: 60 White LED  
Power: 4W  
LED: 260lm 4000K

**Available Colours:**

X=2 White    X=9 Anthracite  
X=3 Black    X=4 Silver

- Recessed wall luminaire
- Die-cast aluminium structure
- Tempered satin glass diffuser
- Aluminium reflector
- Silicon gaskets
- Stainless steel screws
- Technopolymer holder
- Painting using high resistance to UV and corrosion polyester powders

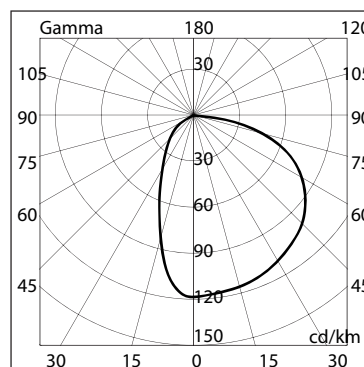

4094 14

