

BL-4090

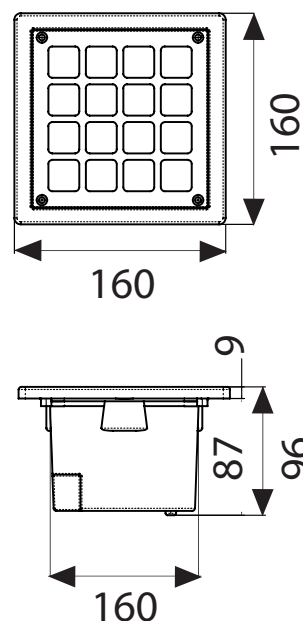

BL-4090.14X

Lamp: QT14
Power: 75W
Base: G9

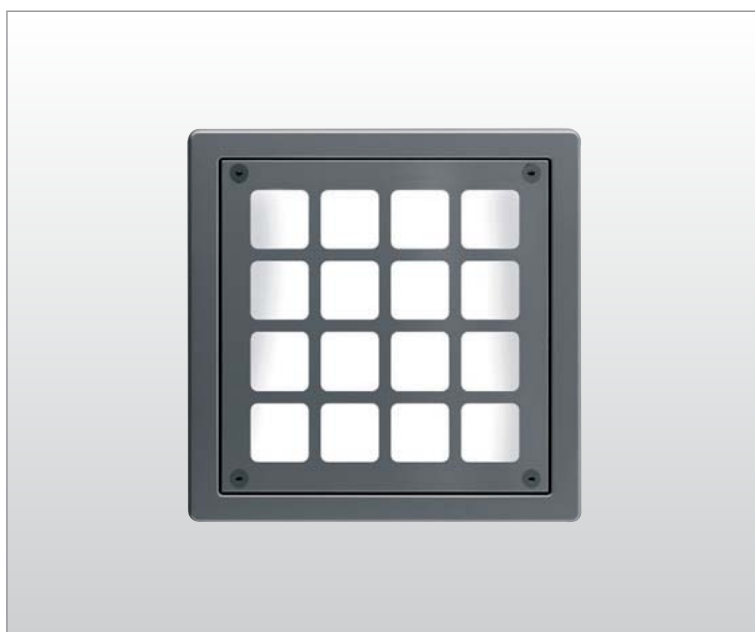



BL-4090.60X

Lamp: T2
Power: 6W
Base: GX53

BL-4090.68X

Lamp: 60 White LED
Power: 4W
Base: GX53

Available Colours:

X=2  White X=9  Anthracite
X=3  Black X=4  Silver

- Recessed wall luminaire
- Die-cast aluminium structure
- Tempered satin glass diffuser
- Aluminium reflector
- Silicon gaskets
- Stainless steel screws
- Technopolymer holder
- Painting using high resistance to UV and corrosion polyester powders

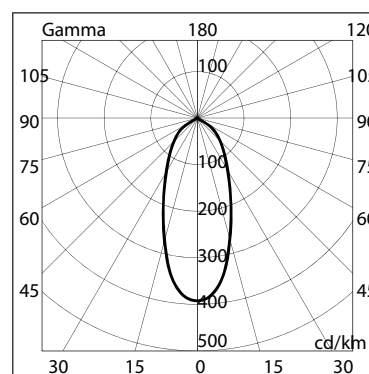

4090 60



Domus Lighting

29-31 Richland Street Kingsgrove NSW 2208

Phone: (02) 9554 9600 | Fax: (02) 9554 9433 | Email: sales@domuslighting.com