

BL-4019

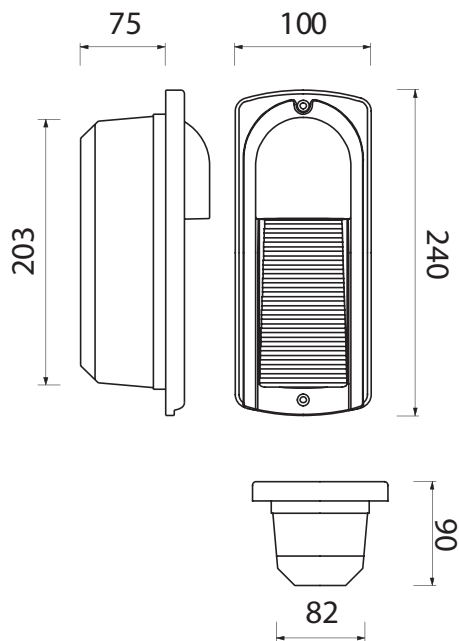



BL-4019.14X

Lamp: QT14
Power: 40W
Base: G9

BL-4019.88X

Lamp: 1 x White LED
Power: 4.1W
LED: 230lm 6300K

Available Colours:

X=3  Black X=9  Anthracite
X=4  Silver

- Indoor and outdoor recessed wall luminaire
- Painted die-cast aluminium structure
- Tempered glass diffuser
- Aluminium reflector
- Silicon gasket
- Stainless steel screws
- Technopolymer wall holder
- Painting using high resistance to UV and corrosion polyester powders

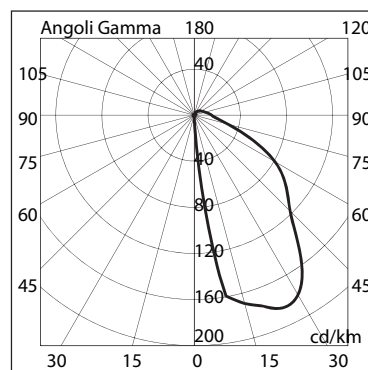

4019 14



Domus Lighting

29-31 Richland Street Kingsgrove NSW 2208
Phone: (02) 9554 9600 | Fax: (02) 9554 9433 | Email: sales@domuslighting.com

