

# BL-3091

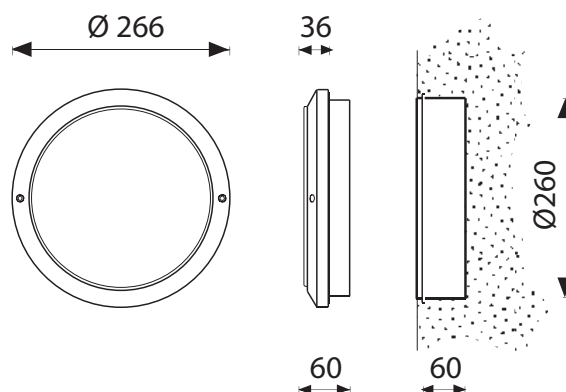

<b>BL-3091.96X</b>	<b>BL-3091.95X</b>
Lamp: TC-D	Lamp: TC-D
Power: 18W	Power: 26W
Base: G24 d-2	Base: G24 d-3

### Colours

X=2		White	X=9		Anthracite
X=3		Black	X=4		Silver

- Recessed wall luminaire
- Die-cast painted aluminium body
- Polycarbonate diffuser
- Aluminium reflector
- EPDM gaskets
- Technopolymer wall holder
- Stainless steel screws
- Painting using high resistance to UV and corrosion polyester powders

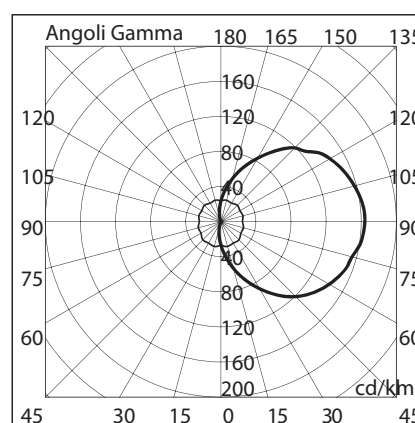

**3091 95**



**Domus Lighting**

29-31 Richland Street Kingsgrove NSW 2208

Phone: (02) 9554 9600 | Fax: (02) 9554 9433 | Email: sales@domuslighting.com

