

BL-3090

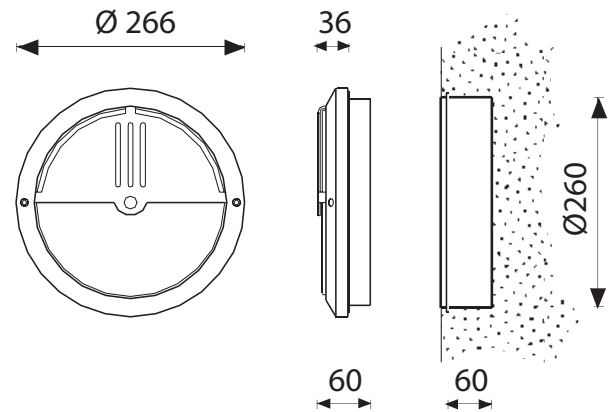

BL-3090.96X

Lamp: TC-D

Power: 18W

Base: G24 d-2

BL-3090.95X

Lamp: TC-D

Power: 26W

Base: G24 d-3

Colours

X=2		White	X=9		Anthracite
X=3		Black	X=4		Silver

- Recessed wall luminaire
- Die-cast painted aluminium body
- Polycarbonate diffuser
- Aluminium reflector
- EPDM gaskets
- Technopolymer wall holder
- Stainless steel screws
- Painting using high resistance to UV and corrosion polyester powders

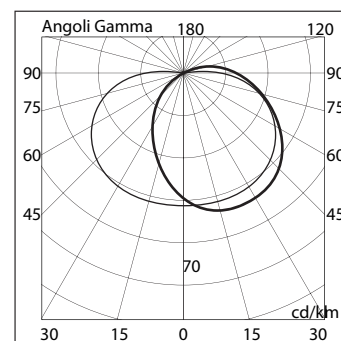

3090 95



Domus Lighting

29-31 Richland Street Kingsgrove NSW 2208

Phone: (02) 9554 9600 | Fax: (02) 9554 9433 | Email: sales@domuslighting.com



Quality
ISO 9001
SAIGLOBAL