

# BL-3073

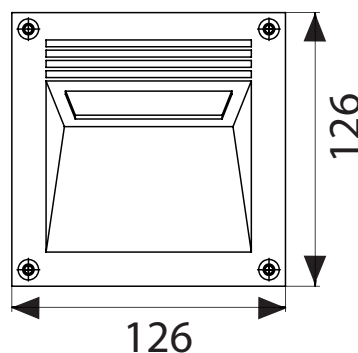
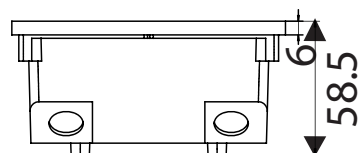

**BL-3073.14X**

Lamp: QT14  
Power: 40W  
Base: G9

**BL-3071.60X**

Lamp: 1 LED  
Power: 4.1W  
Base: 230lm 6300K

**Available Colours:**

- X=2  White
- X=3  Black
- X=4  Silver
- X=9  Anthracite

- Indirect light recessed wall luminaire
- Painted die-cast aluminium body
- Tempered glass diffuser
- Aluminium reflector
- Silicon gaskets
- Stainless steel screws
- Technopolymer wall holder
- Painting using high resistance to UV and corrosion polyester powders

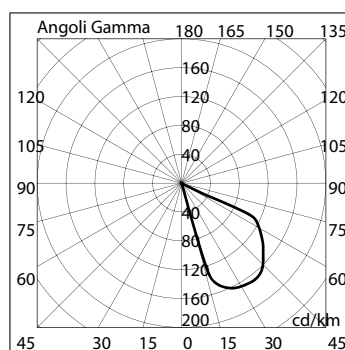

3073 14

