

# BL-3070

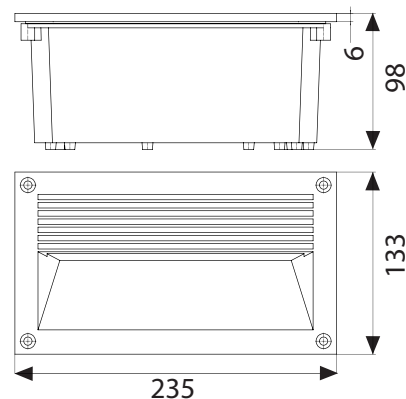

**BL-3070.96X**    **BL-3070.95X**  
Lamp: TC-D      Lamp: TC-D  
Power: 18W      Power: 26W  
Base: G24 d-2    Base: Gx24 d-3

**BL-3070.88X**  
Lamp: 2 LED  
Power: 8.2W  
LED: 460lm 6300K

- Indirect light recessed wall luminaire
- Painted die-cast aluminium body
- Tempered glass diffuser
- Aluminium reflector
- Silicon gaskets
- Stainless steel screws
- Technopolymer wall holder
- Painting using high resistance to UV and corrosion polyester powders

### Available Colours:

X=2 White    X=3 Black  
X=4 Silver    X=9 Anthracite

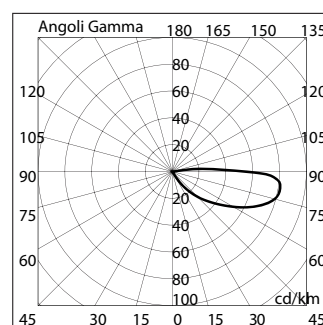

3070 95

