

BL-3060

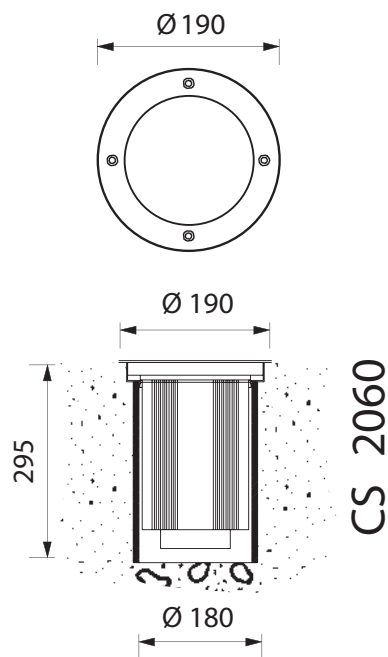

BL-3060.003

Lamp: Q PAR30

Power: 75W

Base: E27

- Outdoor recessed ground luminaire
- Painted die-cast aluminium structure
- Black die-cast aluminium bezel
- Die-cast aluminium diffuser grid (on request)
- Transparent glass
- Aluminium reflector
- Silicon gaskets
- Stainless steel screws
- Polypropylene holder
- Painting using high resistance to UV and corrosion polyester powders

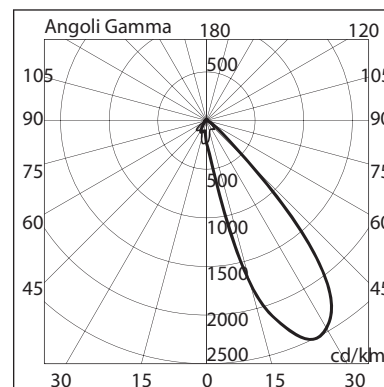

3060 00



Domus Lighting

29-31 Richland Street Kingsgrove NSW 2208

Phone: (02) 9554 9600 | Fax: (02) 9554 9433 | Email: sales@domuslighting.com