

# BL-2075

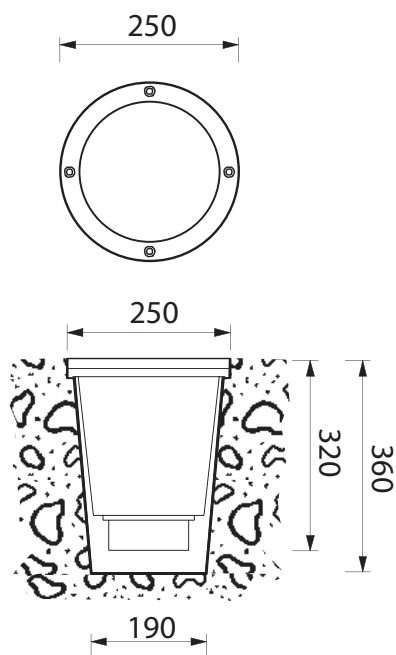

## BL-2075.713

Lamp: HME  
Power: 80W  
Base: E27

- Outdoor recessed ground luminaire
- Painted die-cast aluminium structure
- Die cast aluminium ring
- Die-cast aluminium diffuser grid (on request)
- Satin glass diffuser
- Aluminium symmetrical reflector
- Silicon gaskets
- Stainless steel screws
- Technopolymer holder
- Painting using high resistance to UV and corrosion polyester powders

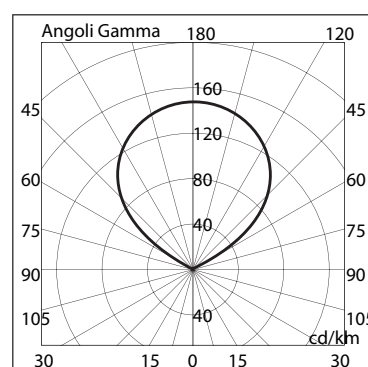

2075 71



**Domus Lighting**

29-31 Richland Street Kingsgrove NSW 2208

Phone: (02) 9554 9600 | Fax: (02) 9554 9433 | Email: sales@domuslighting.com