

BL-2016

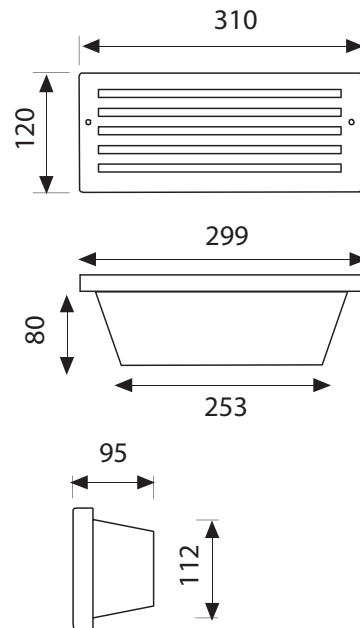

BL-2016.000	BL-2016.960	BL-2016.950
Lamp: A60	Lamp: TC-D	Lamp: TC-D
Power: 60W	Power: 18W	Power: 8.2W
Base: E27	Base: G24 d-2	Base: 460lm 6300K

- Indoor and outdoor recessed wall luminaire
- Die-cast aluminium structure
- Stainless steel cover AISI 316
- Tempered opal glass diffuser
- Silicon gaskets
- Technopolymer wall holder
- Stainless steel screws
- Painting using high resistance to UV and corrosion polyester powders

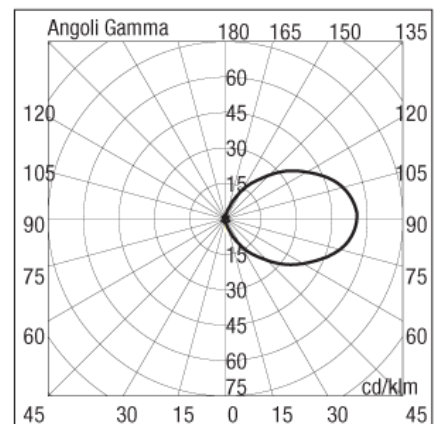

2016 00

