

BL-2010

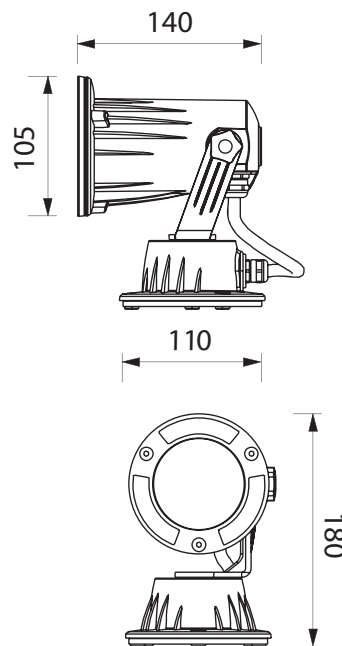



BL-2010.12X

Lamp: QT12
Power: 50W
Base: GY 6.35 12V

BL-2010.14X

Lamp: QT-14
Power: 40W
Base: G9

Available Colours:

X=4  Silver X=9  Anthracite

- Indoor and outdoor spotlight
- Painted die-cast aluminium structure
- Satin tempered glass diffuser for QT12 and QT14 and transparent glass diffuser for QR70
- Aluminium reflector
- Silicon gaskets
- Stainless steel screws
- Painting using high resistance to UV and corrosion polyester powders

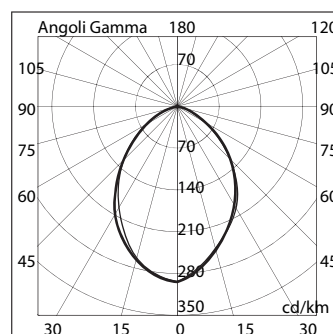

2010 14



Domus Lighting

29-31 Richland Street Kingsgrove NSW 2208

Phone: (02) 9554 9600 | Fax: (02) 9554 9433 | Email: sales@domuslighting.com