

BL-1420

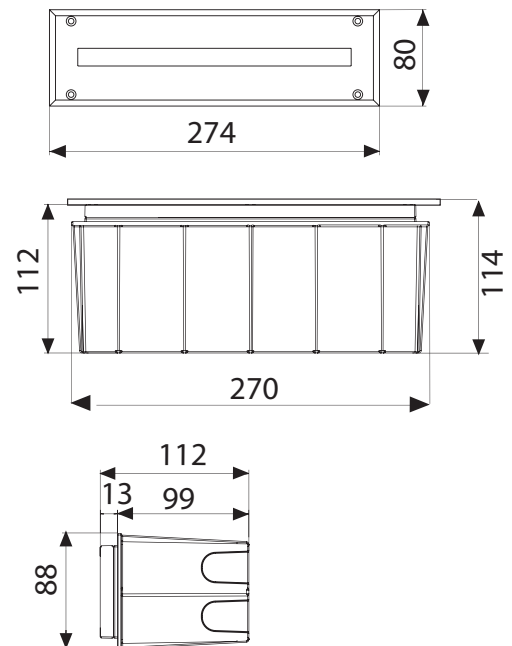

BL-1420.660

Lamp: 5 x White LED
Power: 6W
LED: 675lm 6000K

BL-1420.670

Lamp: 5 x Blue LED
Power: 6W
LED: 370lm

BL-1420.680

Lamp: 5 x Red LED
Power: 6W
LED: 370lm

Stainless Steel Cover

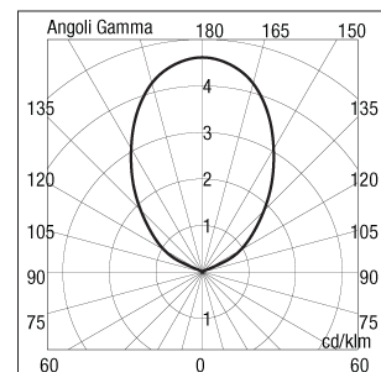

1420 66

- Recessed wall luminaire
- Stainless steel AISI 360 cover
- Aluminium reflector
- Satin tempered glass diffuser
- Silicon gaskets
- Stainless steel screws
- Technopolymer wall holder
- Painting using high resistance to UV and corrosion polyester powders



Domus Lighting

29-31 Richland Street Kingsgrove NSW 2208

Phone: (02) 9554 9600 | Fax: (02) 9554 9433 | Email: sales@domuslighting.com