

BL-1416

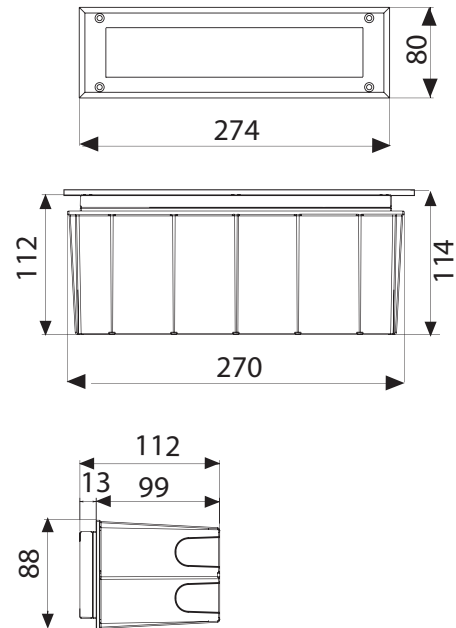
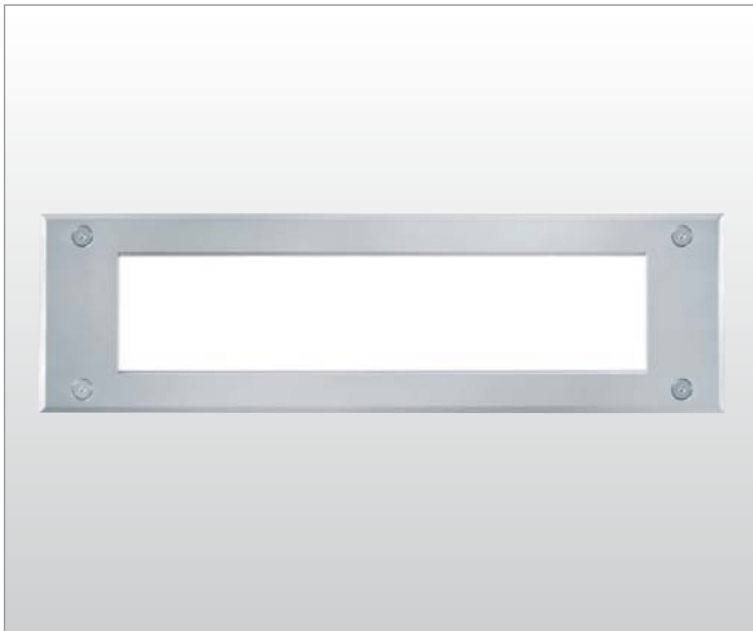

BL-1416.960

Lamp: TC-D
Power: 18W
Base: G24 d-2

BL-1416.660

Lamp: 5 x White LED
Power: 6W
LED: 675lm 6000K

BL-1416.670

Lamp: 5 x Blue LED
Power: 6W
LED: 370lm

BL-1416.680

Lamp: 5 x Red LED
Power: 6W
LED: 370lm

Stainless steel cover

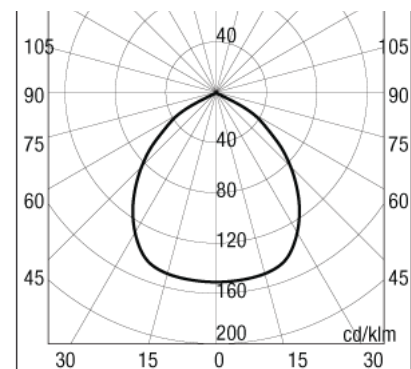

1416 96

- Recessed wall luminaire
- Painted die-cast aluminium body
- Stainless steel AISI 360 cover
- Aluminium reflector
- Satin tempered glass diffuser
- Silicon gaskets
- Stainless steel screws
- Technopolymer wall holder
- Painting using high resistance to UV and corrosion polyester powders



Domus Lighting

29-31 Richland Street Kingsgrove NSW 2208

Phone: (02) 9554 9600 | Fax: (02) 9554 9433 | Email: sales@domuslighting.com



Quality
ISO 9001
SAI GLOBAL